

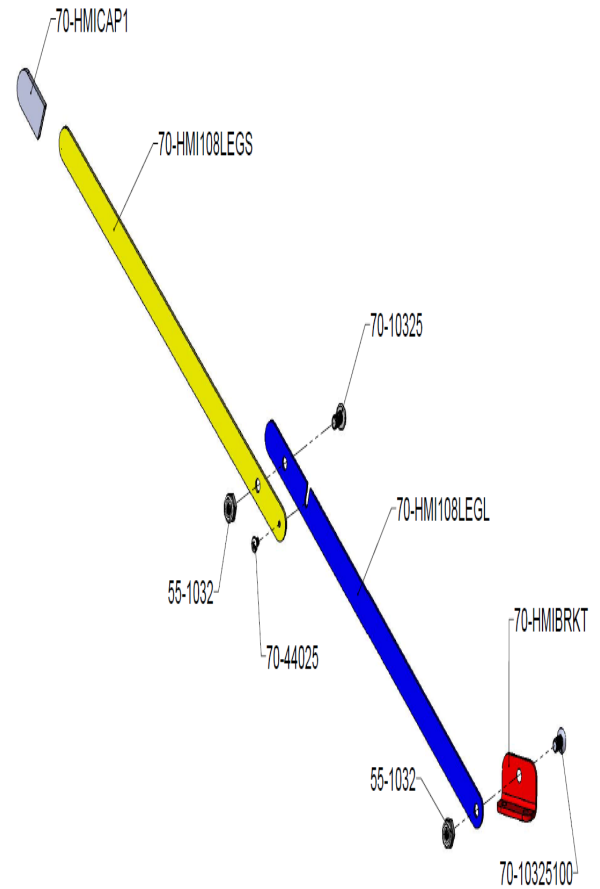

Instructions for Installing HMI Prop Kit Assembly for Right Side Mount

NOTE: Philips Screw Driver and Straight Screw Driver or similar tools and a 3/8" open end wrench is required to install Prop Kit.

1. Place 70-HMICAP1 on top of the (S) LEG (P/N 70-HMI108LEGS).
2. Attach the (S) LEG (P/N 70-HMI108LEGS) to the (L) LEG (P/N 70-HMI108LEGL) by putting (1) #10-32 X 1/2" Pan Head Machine Screw (P/N 70-10325) through the (L) LEG (P/N 70-HMI108LEGL) first then the (S) LEG (P/N 70-HMI108LEGS) and into (1) #10-32 Nylon Insert Locknut (P/N 55-1032), as shown.
3. Install the #4-40 X 1/4" Pan Head Machine Screw (P/N 70-44025) through the (S) LEG (P/N 70-HMI108LEGS) and into the slot of the (L) LEG (P/N 70-HMI108LEGL), as shown.
4. Attach the (L) LEG (P/N 70-HMI108LEGL) to the Prop Bracket (P/N 70-HMIBRKT) by installing (1) #10-32 X 1/2" Flat Head Screw (P/N 70-10325100) through the back of the bracket and the (L) LEG (P/N 70-HMI108LEGL) and into (1) #10-32 Nylon Insert Locknut (P/N 55-1032).
5. Hardware included:
 - 70-HMICAP1, HMI Prop Cap, qty. 1
 - 70-10325, 10-32 X 1/2" Pan Head Machine Screw, qty. 1
 - 55-1032, 10-32 Nylon Insert Locknut, qty. 2
 - 70-44025, 4-40 X 1/4" Pan Head Machine Screw, qty. 1
 - 70-10325100, 10-32 X 1/2" Flat Head Screw, qty. 1
 - 70-HMIBRKT, HMI Prop Bracket, qty. 1
 - 70-HMI108LEGS, (S) LEG
 - 70-HMI108LEGL, (L) LEG
 - 70-10165, 10-16 X 1/2" Pan Head Thread Forming Screw, qty. 1



Instructions for Mounting HMI Prop Kit to Right Side of HMI Cover

1. Mount Prop Kit to the small frame hole as shown.
2. Attach Prop Kit Assembly to HMI Cover by screwing it into the cover with a #10-32 X 1/2" Pan Head Machine Screw (P/N 70-10165). Hardware Torque Specifications 25-30 in-lbs.

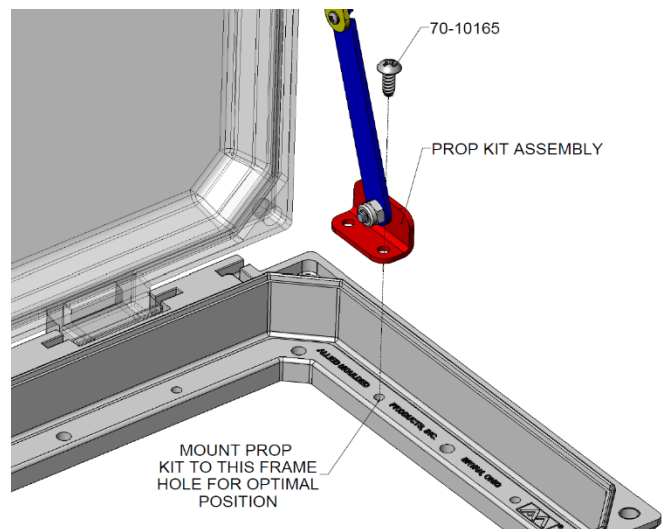



Instructions for Installing HMI Prop Kit Assembly for left side mount

1. Place 70-HMICAP1 on top of the (S) LEG.
2. Attach the (S) LEG to the (L) LEG (P/N 70-HMI108LEGL) by putting (1) #10-32 X 1/2" Pan Head Machine Screw (P/N 70-10325) through the (L) LEG (P/N 70-HMI108LEGL) first then the (S) LEG and into (1) #10-32 Nylon Insert Locknut (P/N 55-1032), as shown.
3. Install the #4-40 X 1/4" Pan Head Machine Screw (P/N 70-44025) through the (S) LEG and into the slot of the (L) LEG (P/N 70-HMI108LEGL), as shown.
4. Attach the (L) LEG (P/N 70-HMI108LEGL) to the Prop Bracket (P/N 70-HMIBRKT) by installing (1) #10-32 X 1/2" Flat Head Screw (P/N 70-10325100) through the back of the bracket and the (L) LEG (P/N 70-HMI108LEGL) and into (1) #10-32 Nylon Insert Locknut (P/N 55-1032).

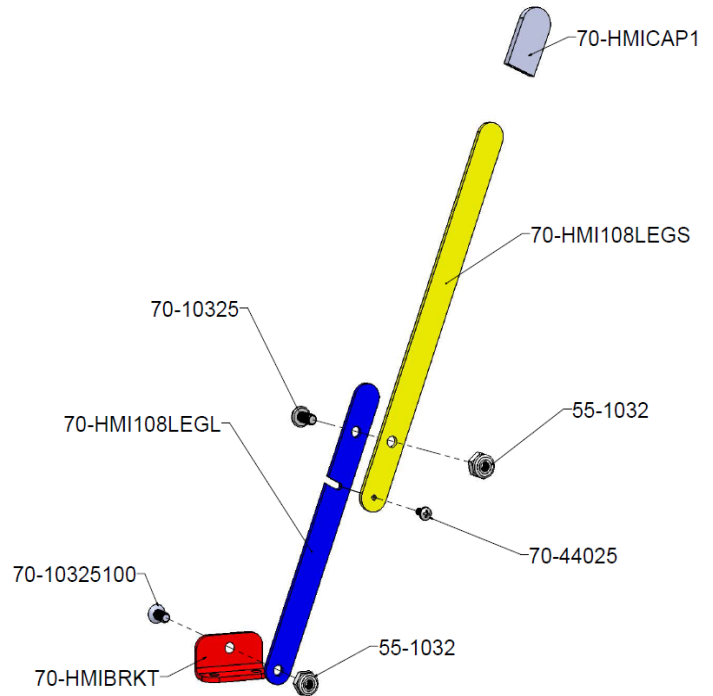

Instructions for Mounting HMI Prop Kit to Left Side of HMI Cover

1. Mount Prop Kit to the small frame hole as shown.
2. Attach Prop Kit Assembly to HMI Cover by screwing it into the cover with a #10-32 X 1/2" Pan Head Machine Screw (P/N 70-10165). Hardware Torque Specifications 25-30 in-lbs.

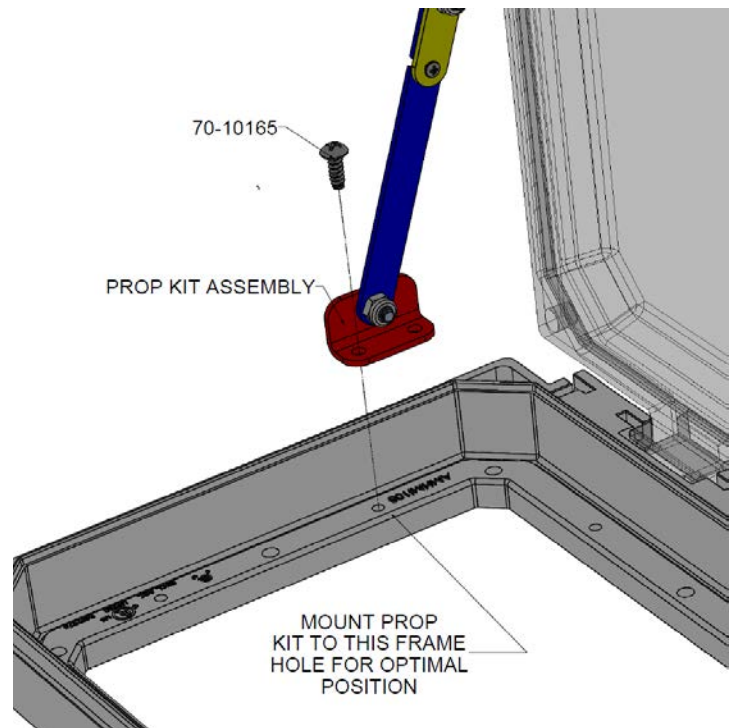

Allied Moulded Products, Inc.
222 North Union Street • Bryan, Oh 43506
Phone: 1-800-722-2679 • Fax: 1-800-237-7269
www.alliedmoulded.com