

(4) EACH #10-32 BRASS INSERTS AND 316 STAINLESS STEEL CAPTIVE COVER SCREWS WITH RETAINING O-RING

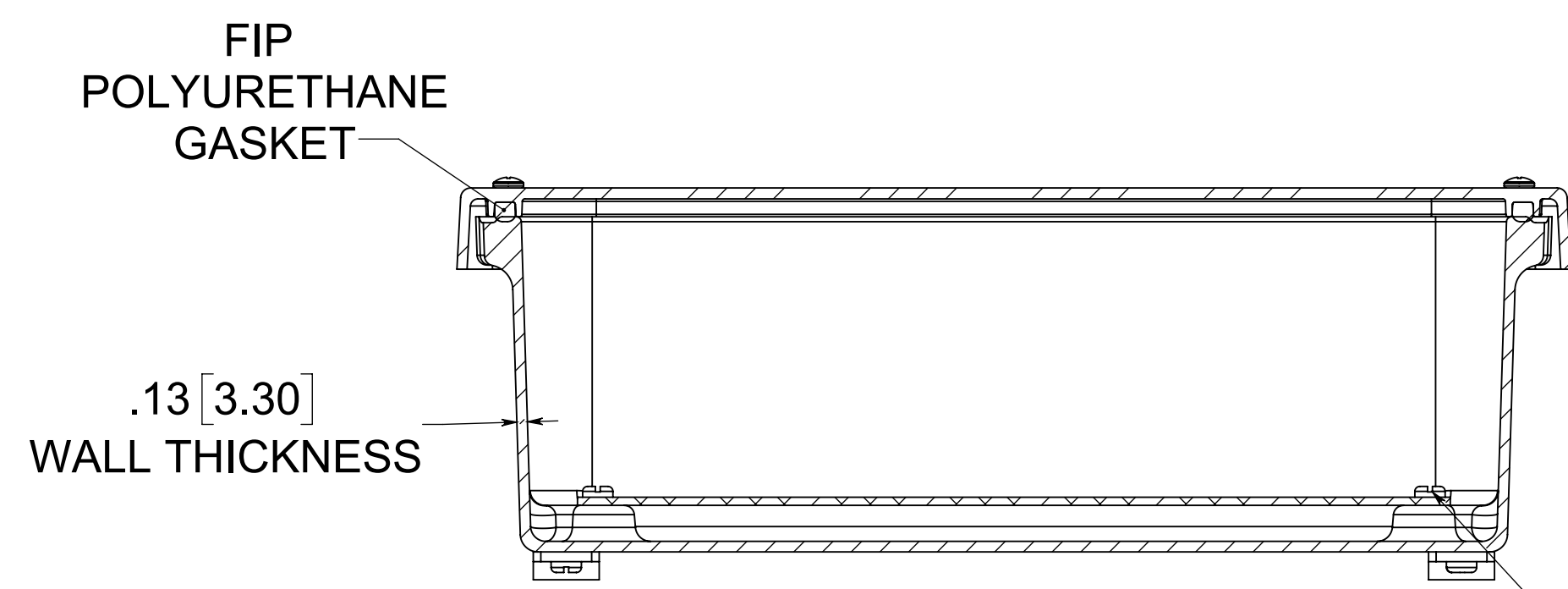

SECTION B-B

(4) EACH #10-32 BRASS INSERTS AND PLATED CARBON SCREWS

MATERIAL:
 BOX-COMPRESSION MOLDED FIBERGLASS REINFORCED POLYESTER
 COVER-COMPRESSION MOLDED FIBERGLASS REINFORCED POLYESTER
 WINDOWS-POLYCARBONATE

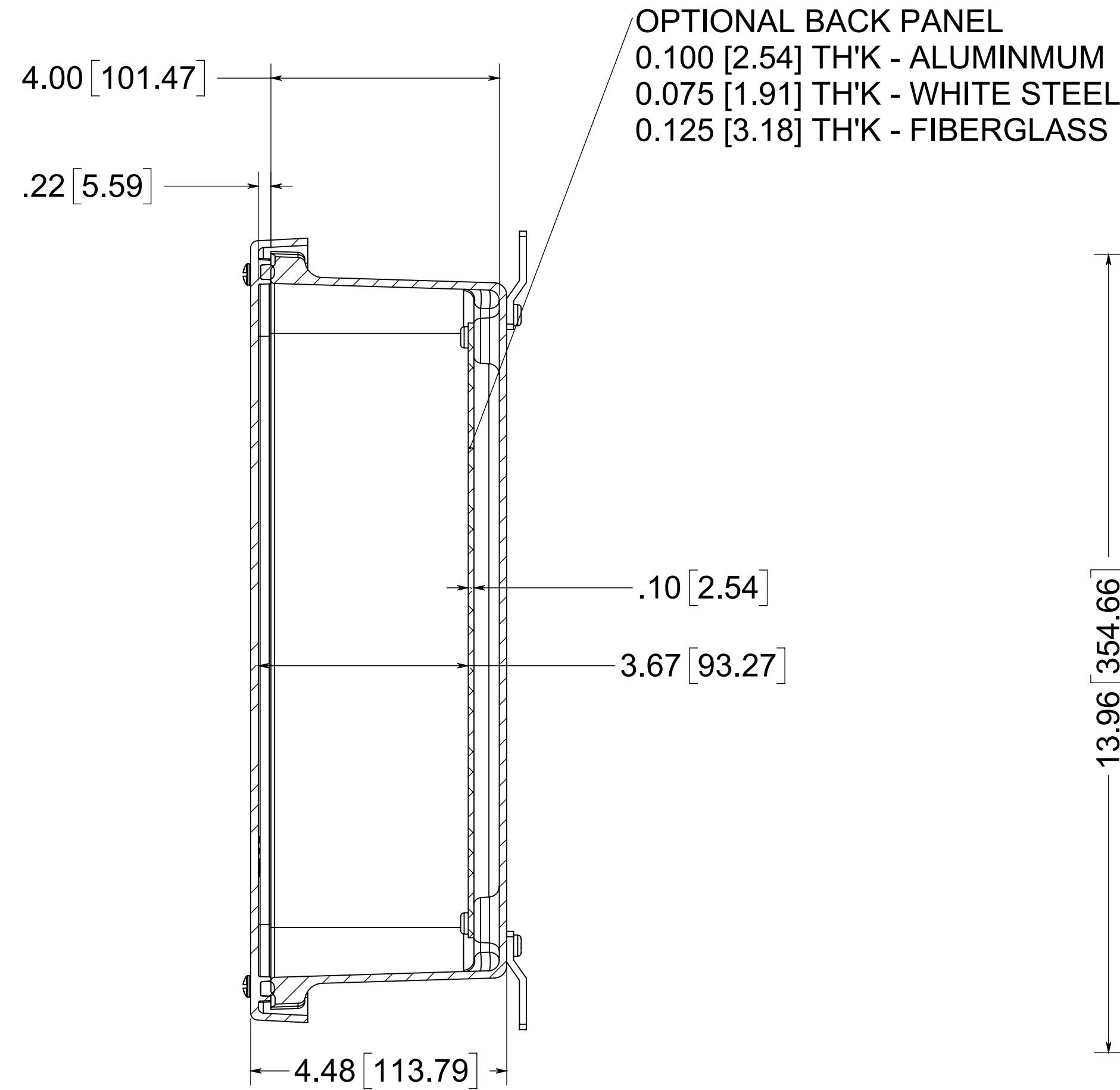

SECTION A-A

OPTIONAL BACK PANEL
 0.100 [2.54] TH'K - ALUMINUM
 0.075 [1.91] TH'K - WHITE STEEL
 0.125 [3.18] TH'K - FIBERGLASS

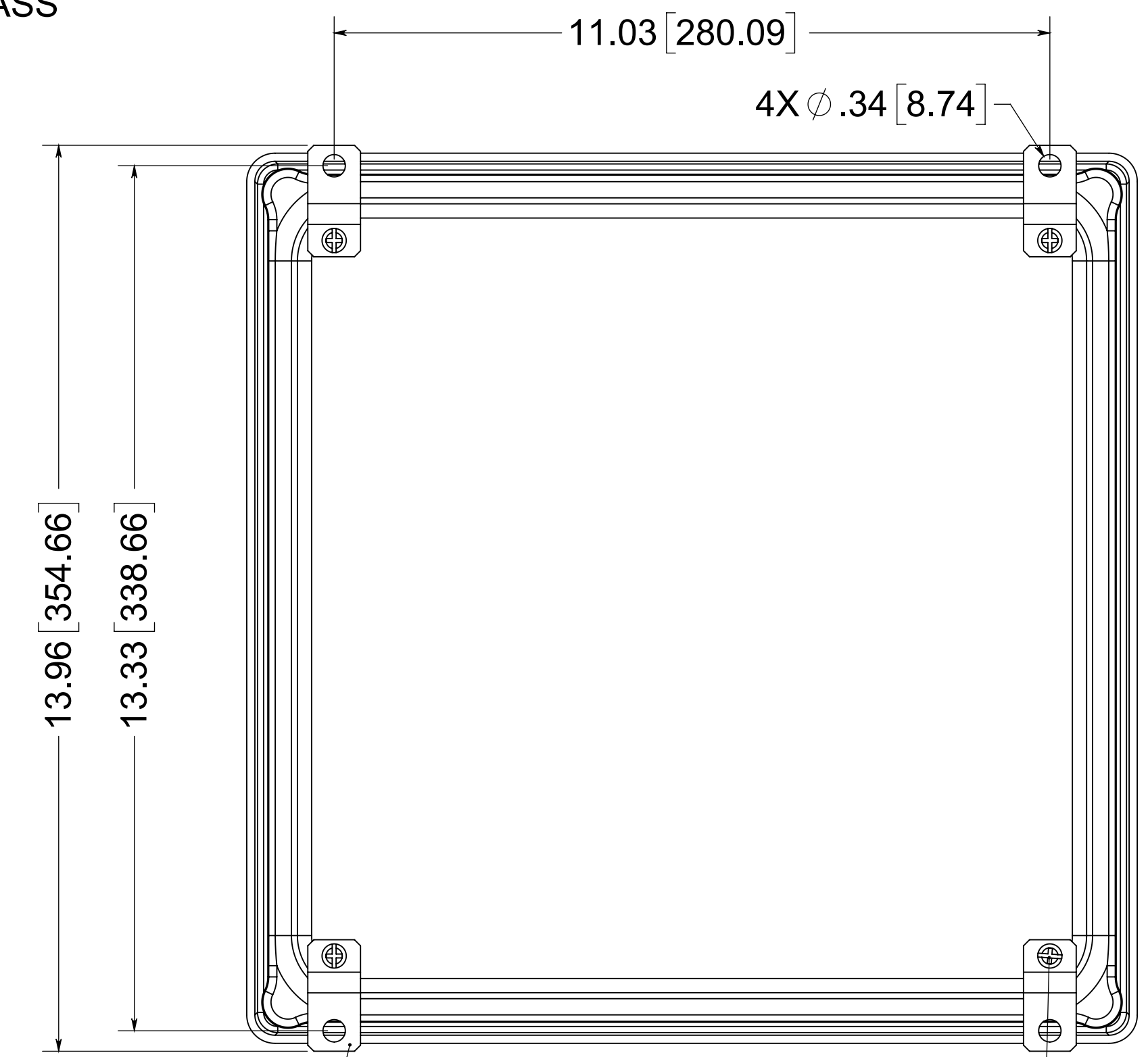

(4) 316 STAINLESS STEEL MOUNTING FEET

(4) EACH #10-32 BRASS INSERTS, AND 316 STAINLESS STEEL FEET SCREWS

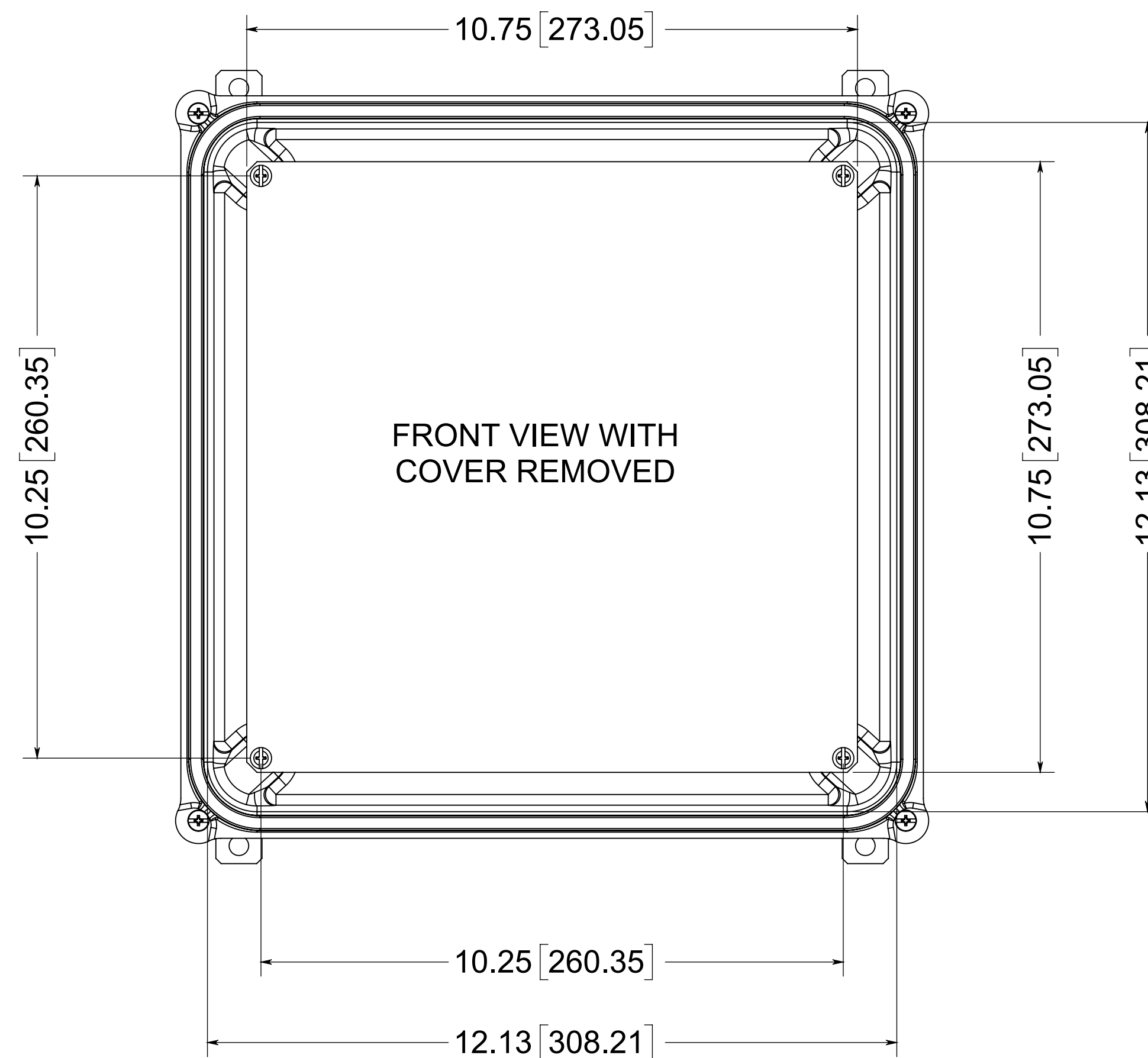

FRONT VIEW WITH COVER REMOVED

NOTE:
 1. DATA SUBJECT TO CHANGE WITHOUT NOTICE

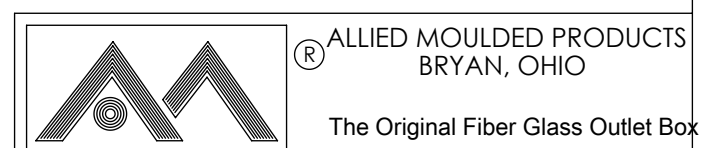

CONFIDENTIAL
 THIS MATERIAL IS OWNED BY THE ALLIED MOULDED PRODUCTS COMPANY, IS DISCLOSED IN CONFIDENCE, AND IS NOT TO BE REPRODUCED OR DISTRIBUTED WITHOUT PRIOR WRITTEN PERMISSION FROM ALLIED MOULDED PRODUCTS.

Description
AM Series
 Part No.
AM1224