

Date	Rev	Description	ECN No.	ISSUE DATE	DR	CK	REL
03/13/2018		INITIAL RELEASE	ECN-12522		DJL	SRH	GEL
-	-	-	-	-	-	-	-
-	-	-	-	-	-	-	-

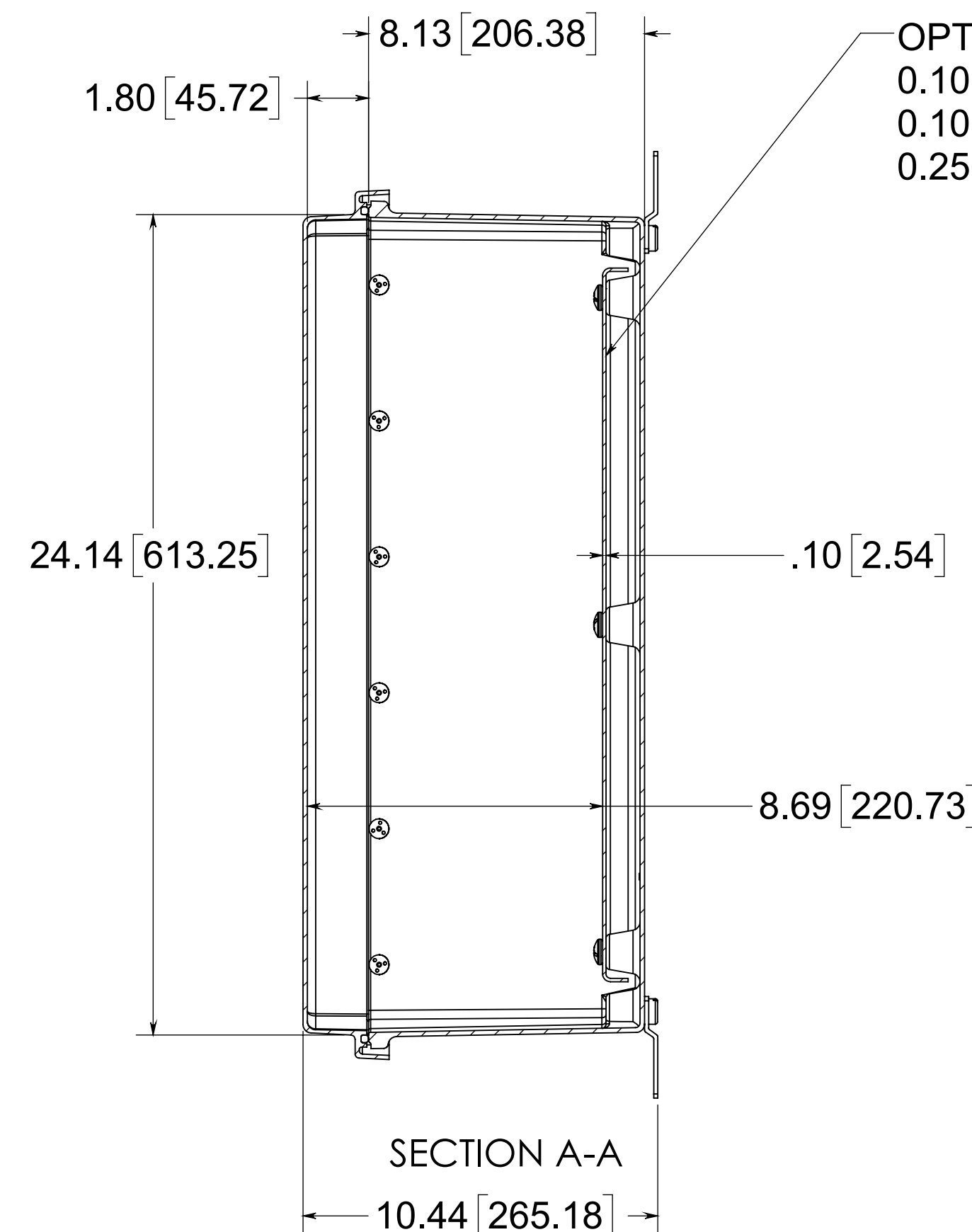

OPTIONAL BACK PANEL  
 0.100 [2.54] TH'K- ALUMINUM  
 0.105 [2.67] TH'K- WHITE STEEL  
 0.250 [6.35] TH'K- FIBERGLASS

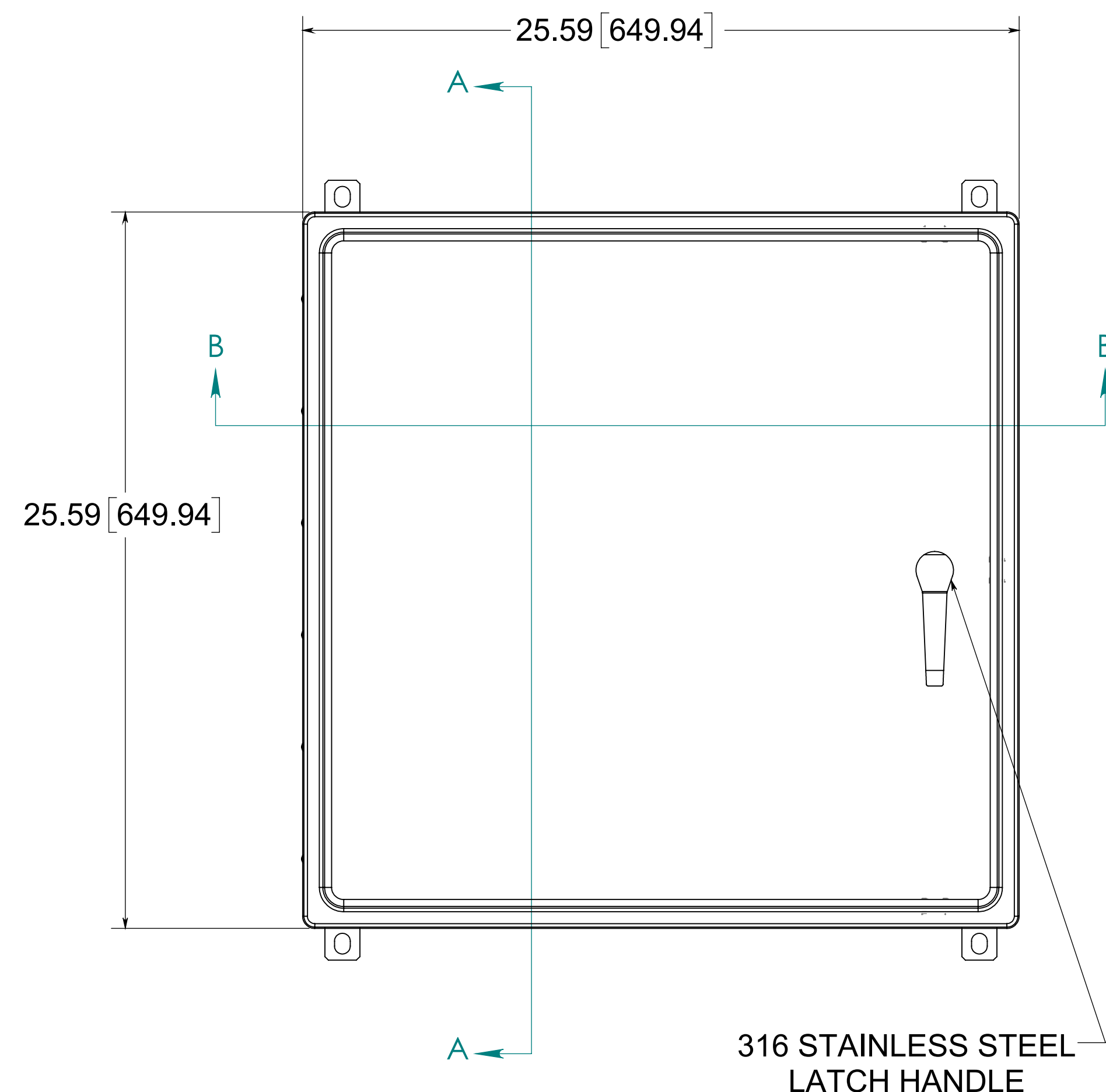
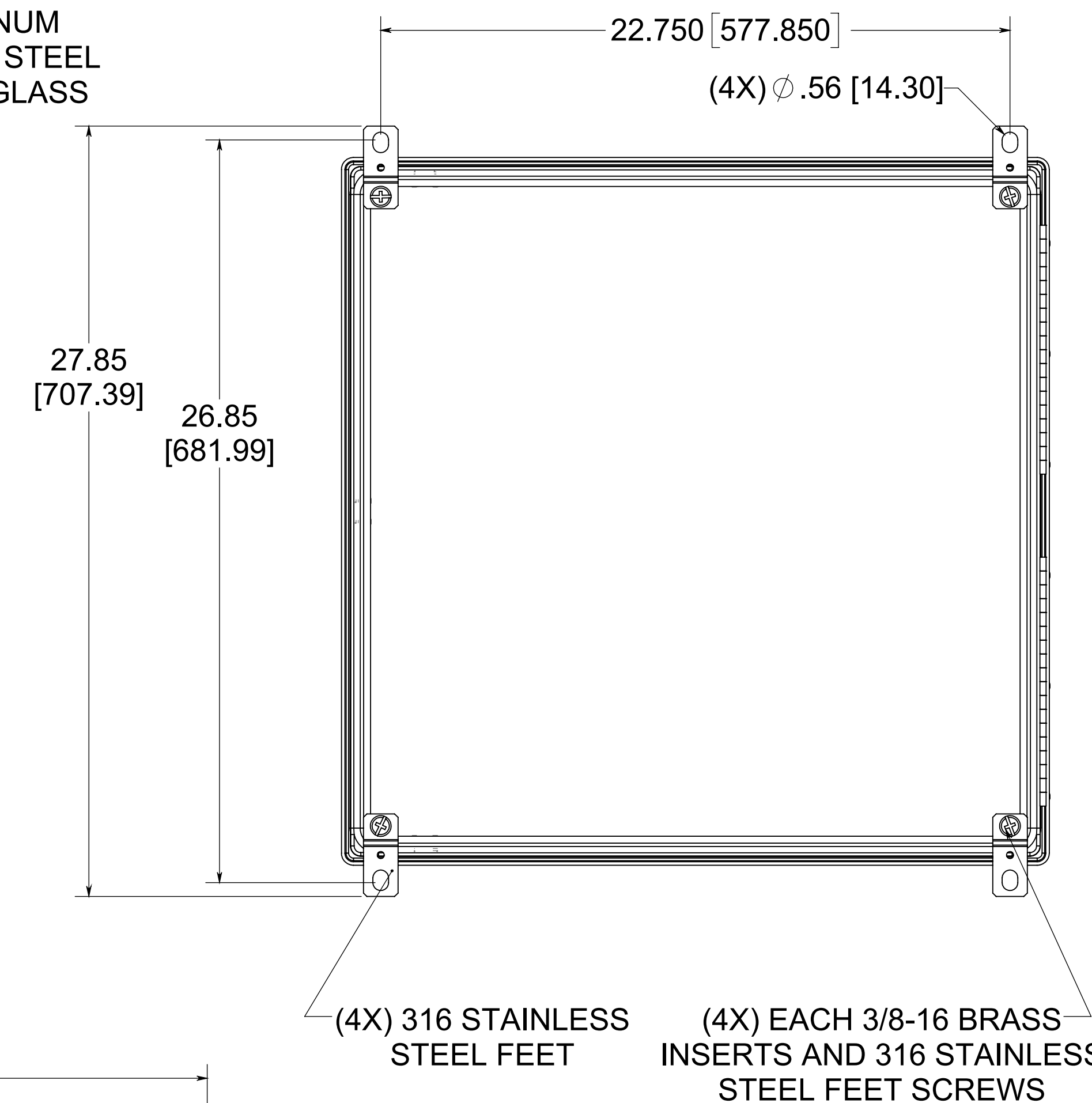

(4X) 316 STAINLESS STEEL FEET  
 (4X) EACH 3/8-16 BRASS INSERTS AND 316 STAINLESS STEEL FEET SCREWS

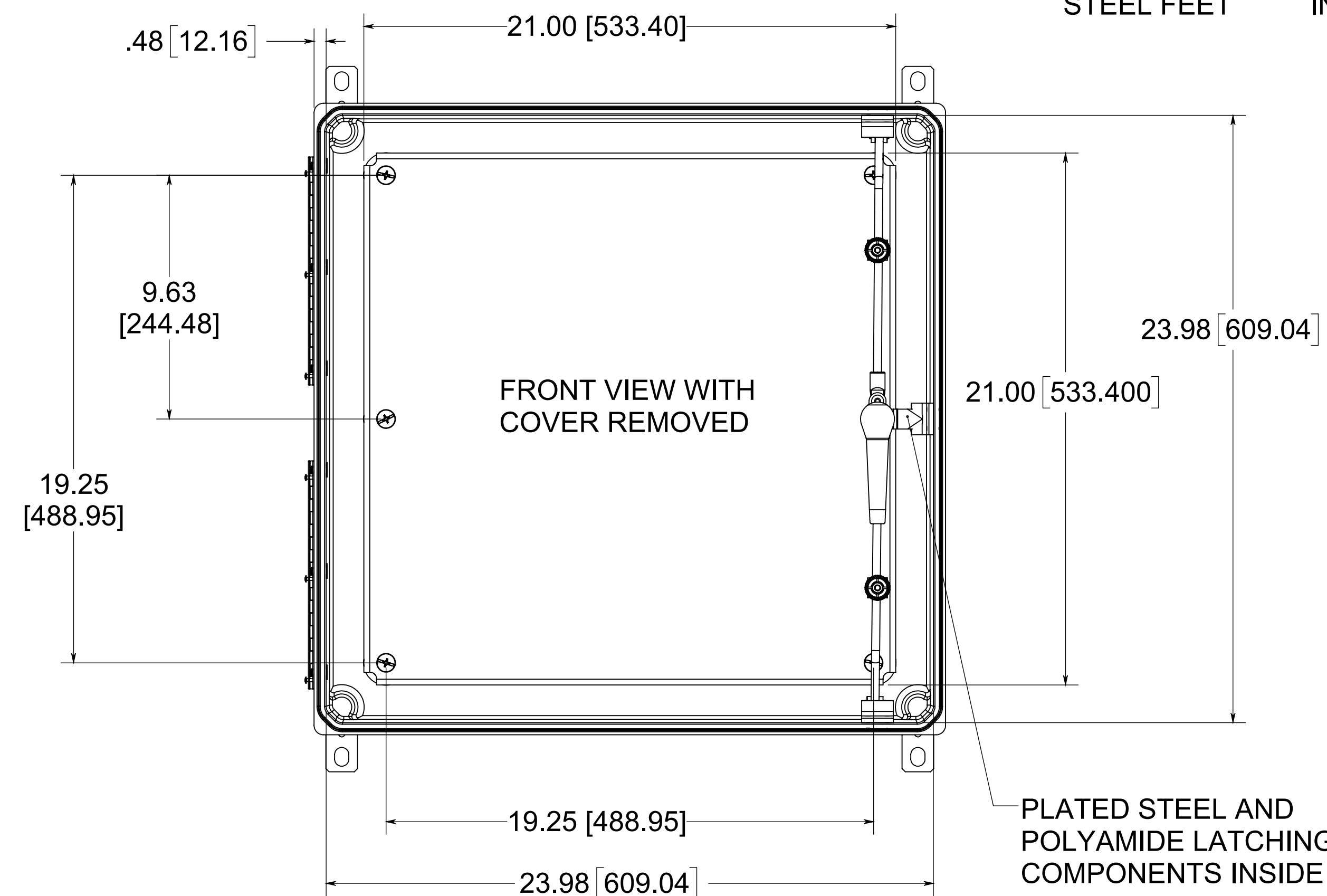
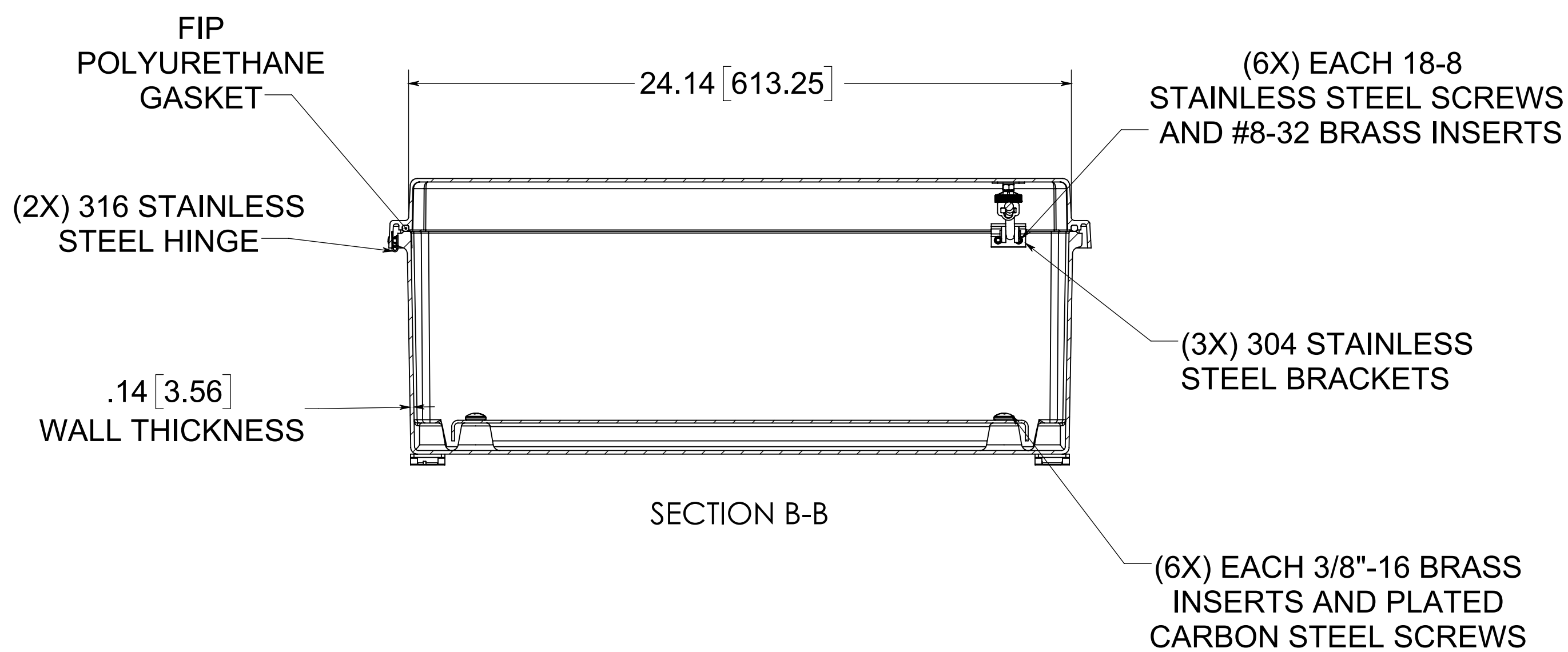

PLATED STEEL AND POLYAMIDE LATCHING COMPONENTS INSIDE

NOTE:  
 1. DATA SUBJECT TO CHANGE WITHOUT NOTICE

MATERIAL:  
 BOX- COMPRESSION MOLDED FIBERGLASS REINFORCED POLYESTER  
 COVER- COMPRESSION MOLDED FIBERGLASS REINFORCED POLYESTER  
 WINDOW- POLYCARBONATE

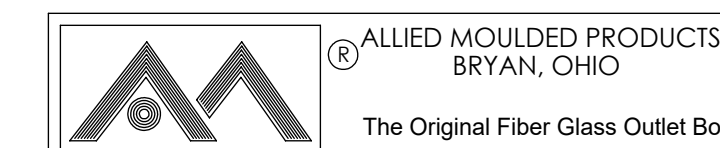

CONFIDENTIAL  
 THIS MATERIAL IS OWNED BY THE ALLIED MOULDED PRODUCTS COMPANY, IS DISCLOSED IN CONFIDENCE, AND IS NOT TO BE REPRODUCED OR DISTRIBUTED WITHOUT PRIOR WRITTEN PERMISSION FROM ALLIED MOULDED PRODUCTS.  
 © Allied Moulded Products, Inc. All Rights Reserved

Description  
**Control**  
 Part No.  
**AM24248R3PT**