

Date	Rev	Description	ECN No.	ISSUE DATE	DR	CK	REL
03/02/2018		INITIAL RELEASE	ECN-12512		DJL	SRH	GEL
-	-	-	-	-	-	-	-
-	-	-	-	-	-	-	-

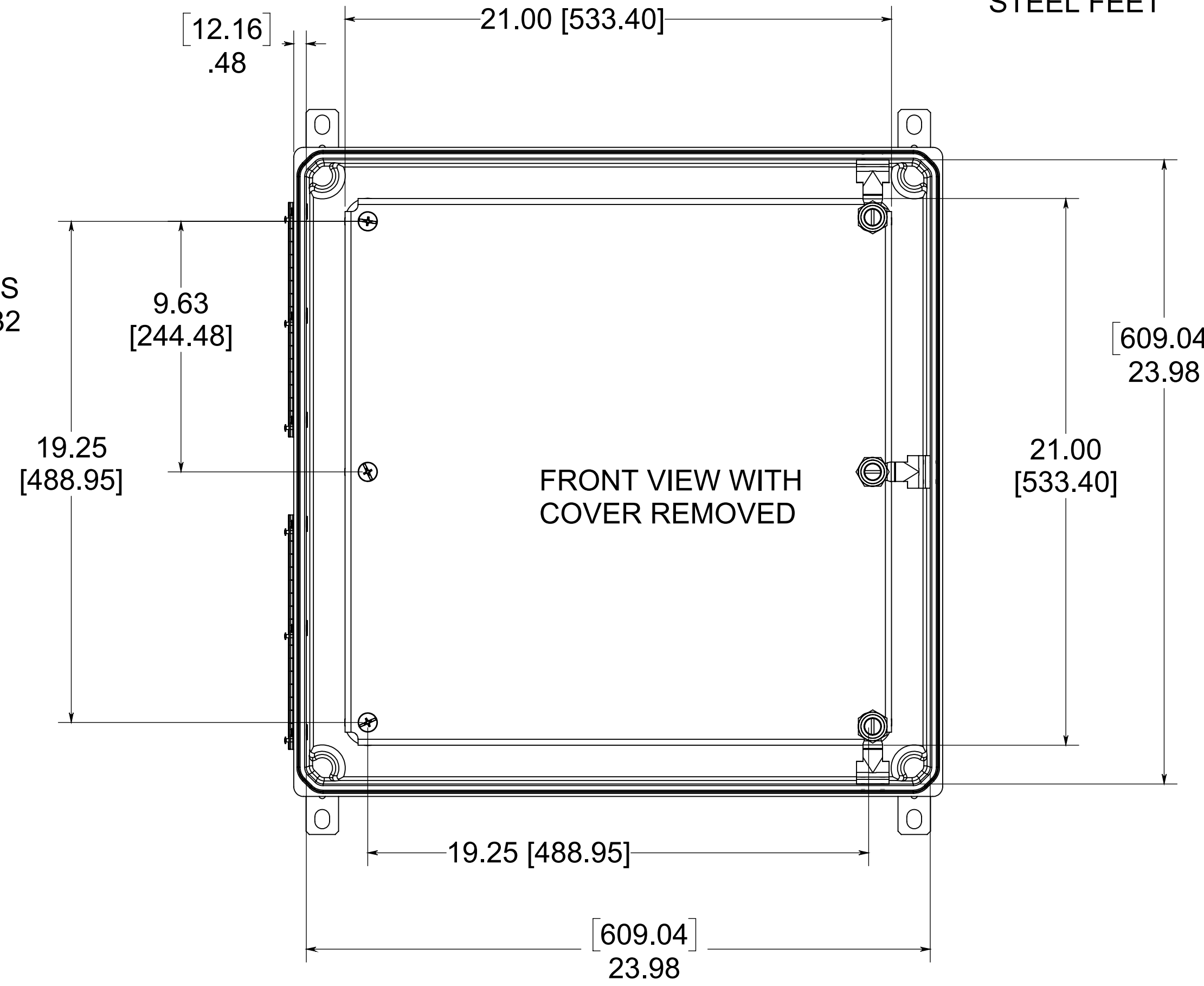
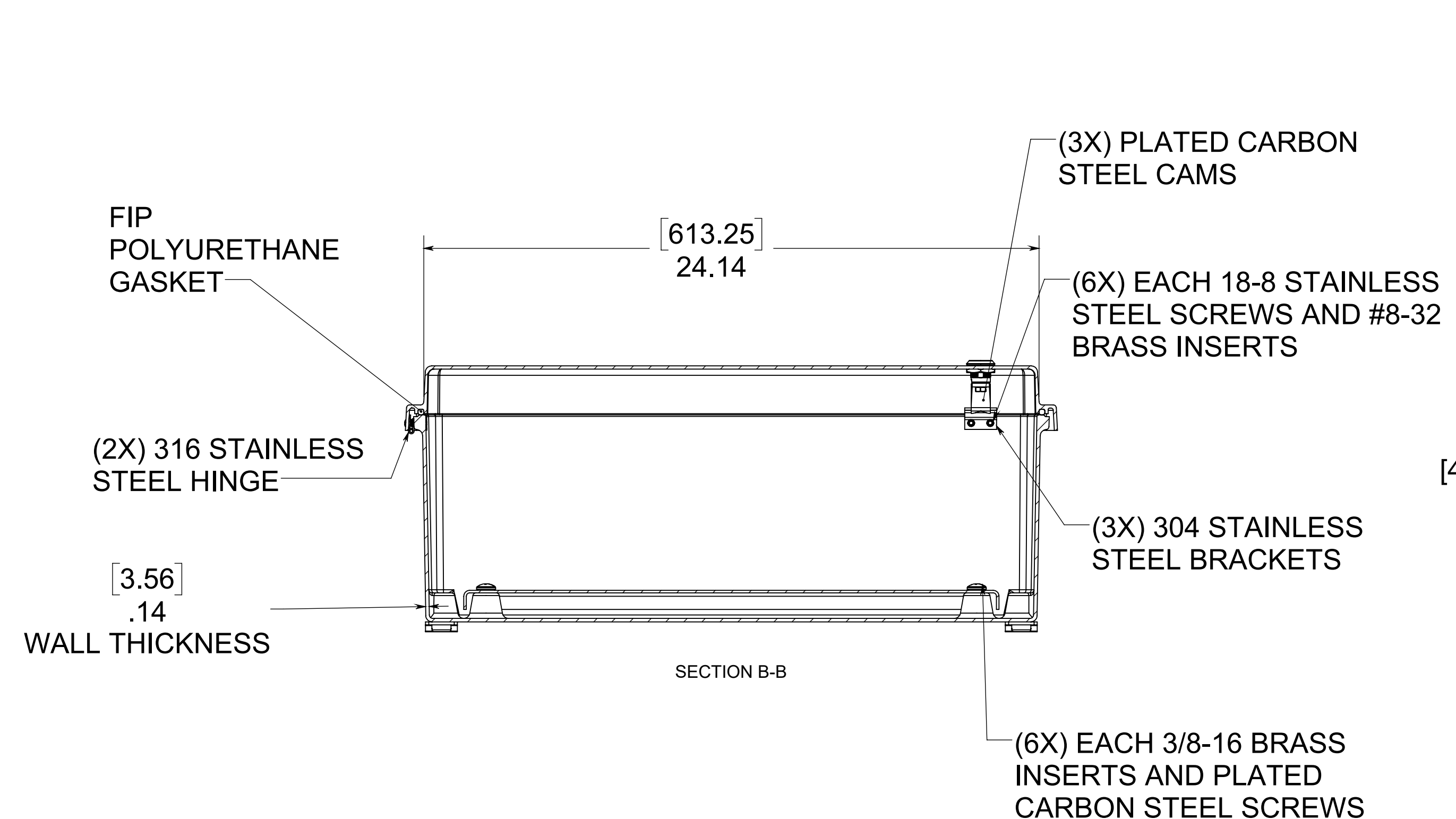
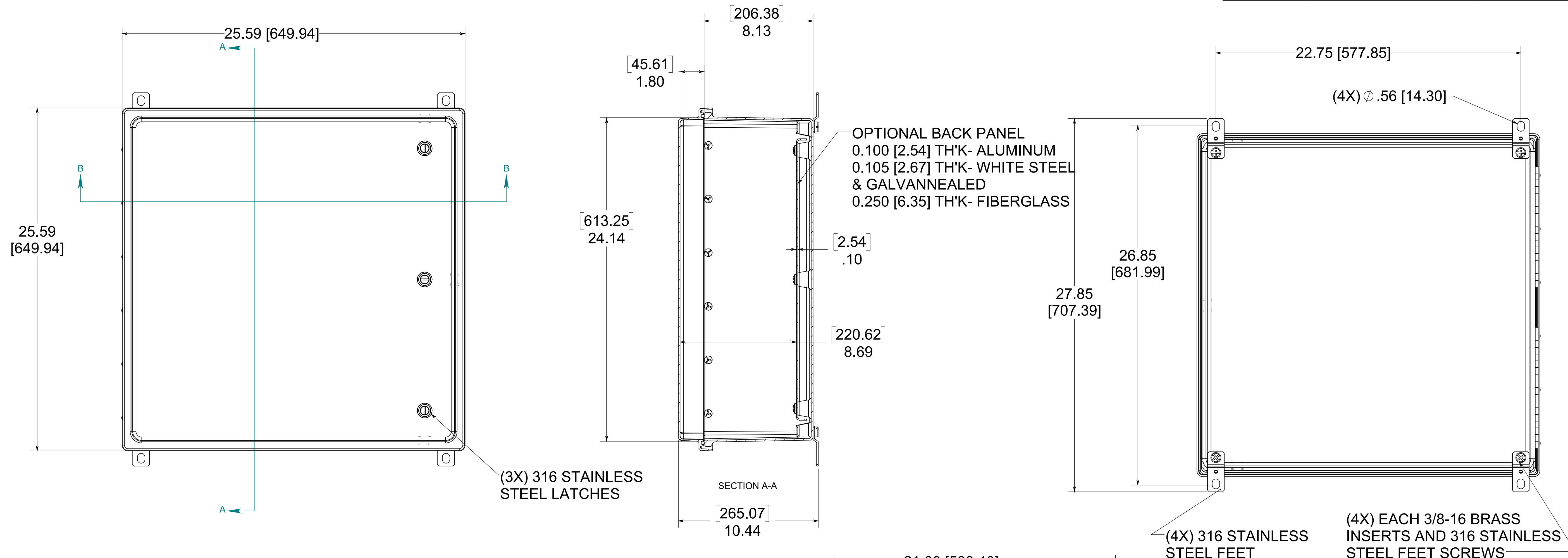

NOTE:
 1. DATA SUBJECT TO CHANGE WITHOUT NOTICE

MATERIAL:
 BOX- COMPRESSION MOLDED FIBERGLASS REINFORCED POLYESTER
 COVER- COMPRESSION MOLDED FIBERGLASS REINFORCED POLYESTER
 WINDOW-- POLYCARBONATE

ALLIED MOULDED PRODUCTS
 BRYAN, OHIO
 The Original Fiber Glass Outlet Box

CONFIDENTIAL
 THIS MATERIAL IS OWNED BY THE ALLIED MOULDED PRODUCTS COMPANY, IS DISCLOSED IN CONFIDENCE, AND IS NOT TO BE REPRODUCED OR DISTRIBUTED WITHOUT PRIOR WRITTEN PERMISSION FROM ALLIED MOULDED PRODUCTS.
 © Allied Moulded Products, Inc. All Rights Reserved

Part No. **CONTROL**
AM24248RQT