

Date	Rev	Description	ECN No.	ISSUE DATE	DR	CK	REL
07/25/2019		INITIAL RELEASE	ECN-302		DJL	LJS	GEL
-	-	-	-	-	-	-	-
-	-	-	-	-	-	-	-

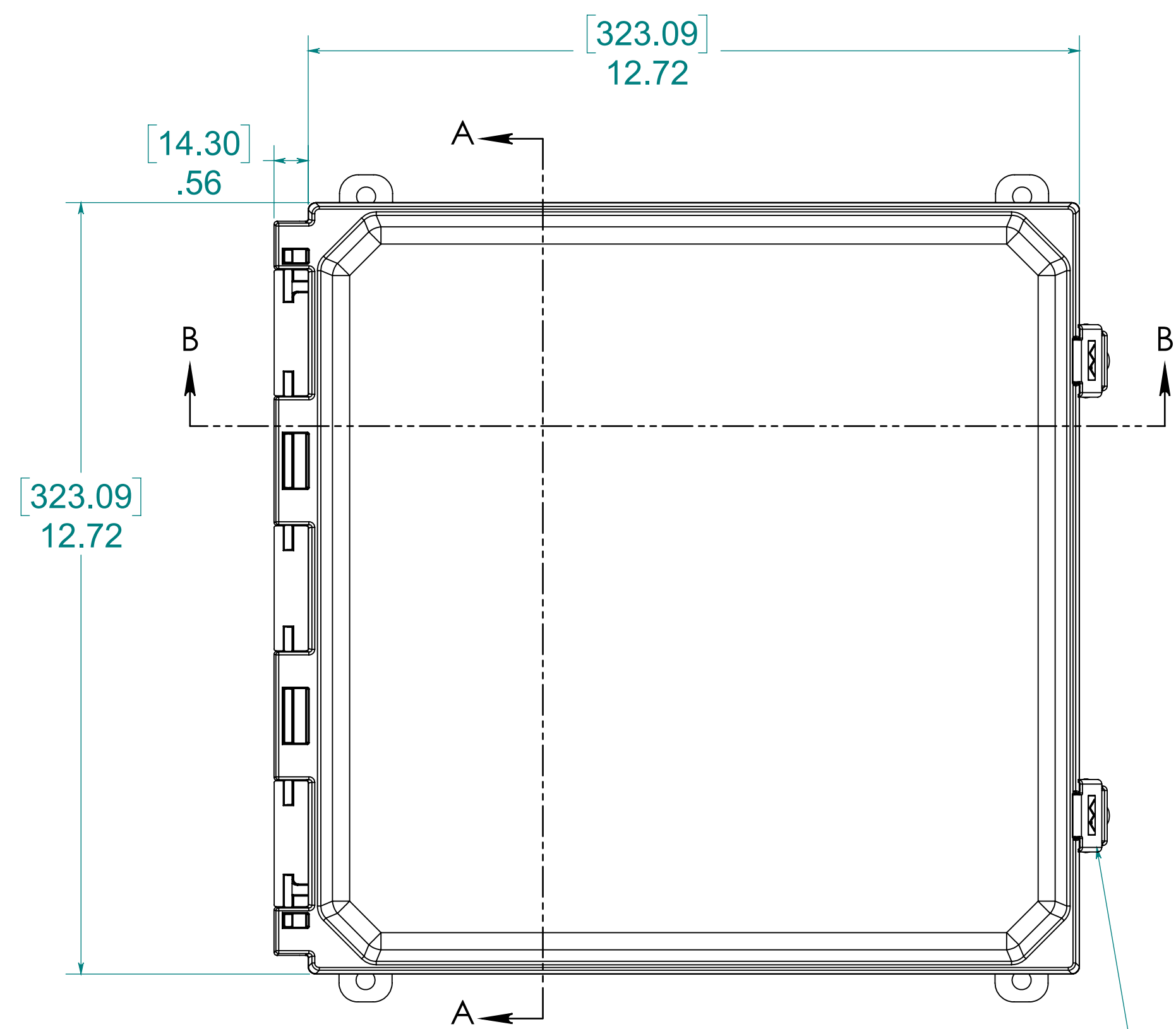

(2X) 316 STAINLESS STEEL LOCKABLE SNAP LATCH

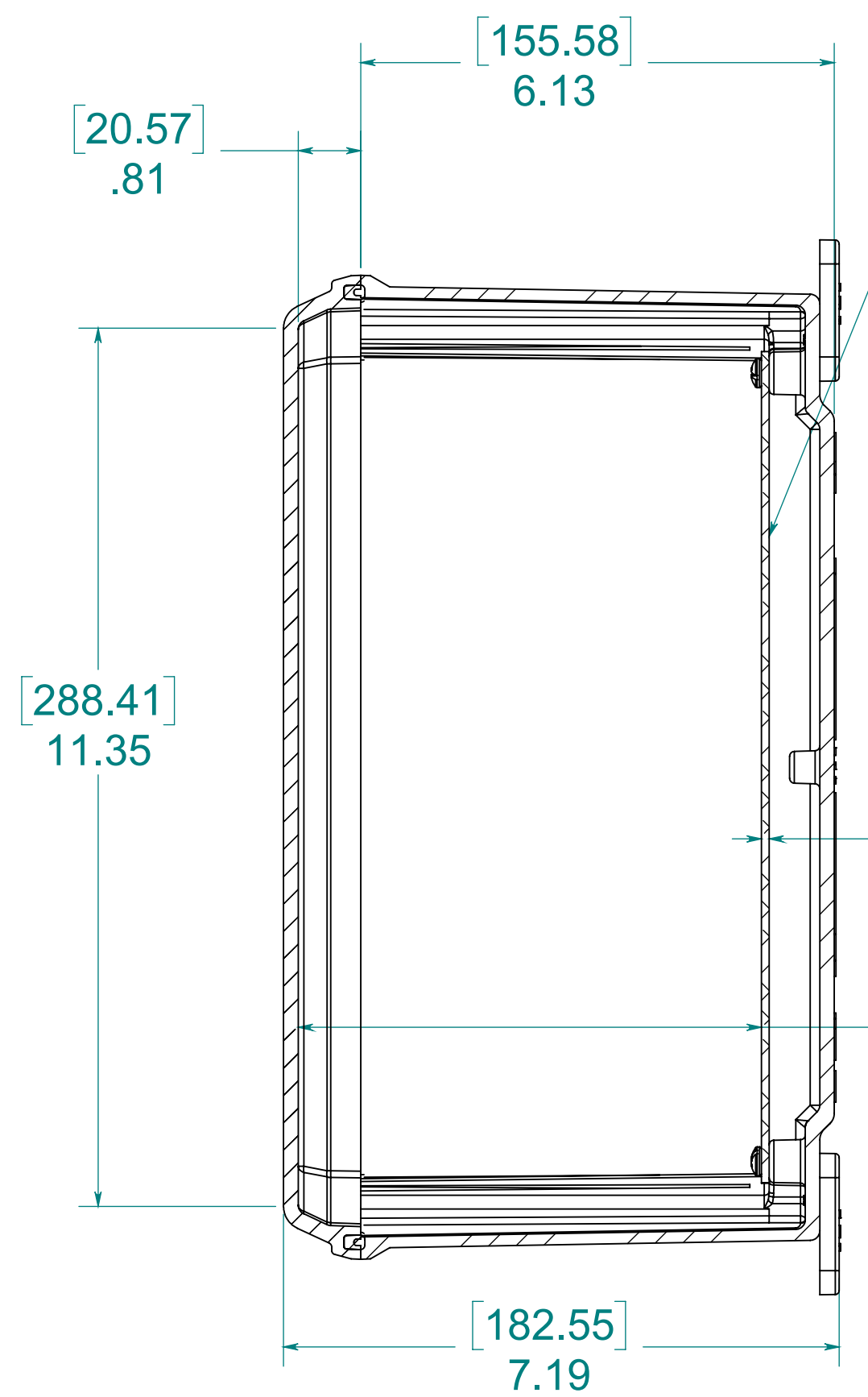

SECTION A-A

OPTIONAL BACK PANEL SHOWN
 0.100 [2.54mm] TH'K- ALUMINUM
 0.075 [1.91mm] TH'K- WHITE STEEL
 0.188 [4.78mm] TH'K- PVC

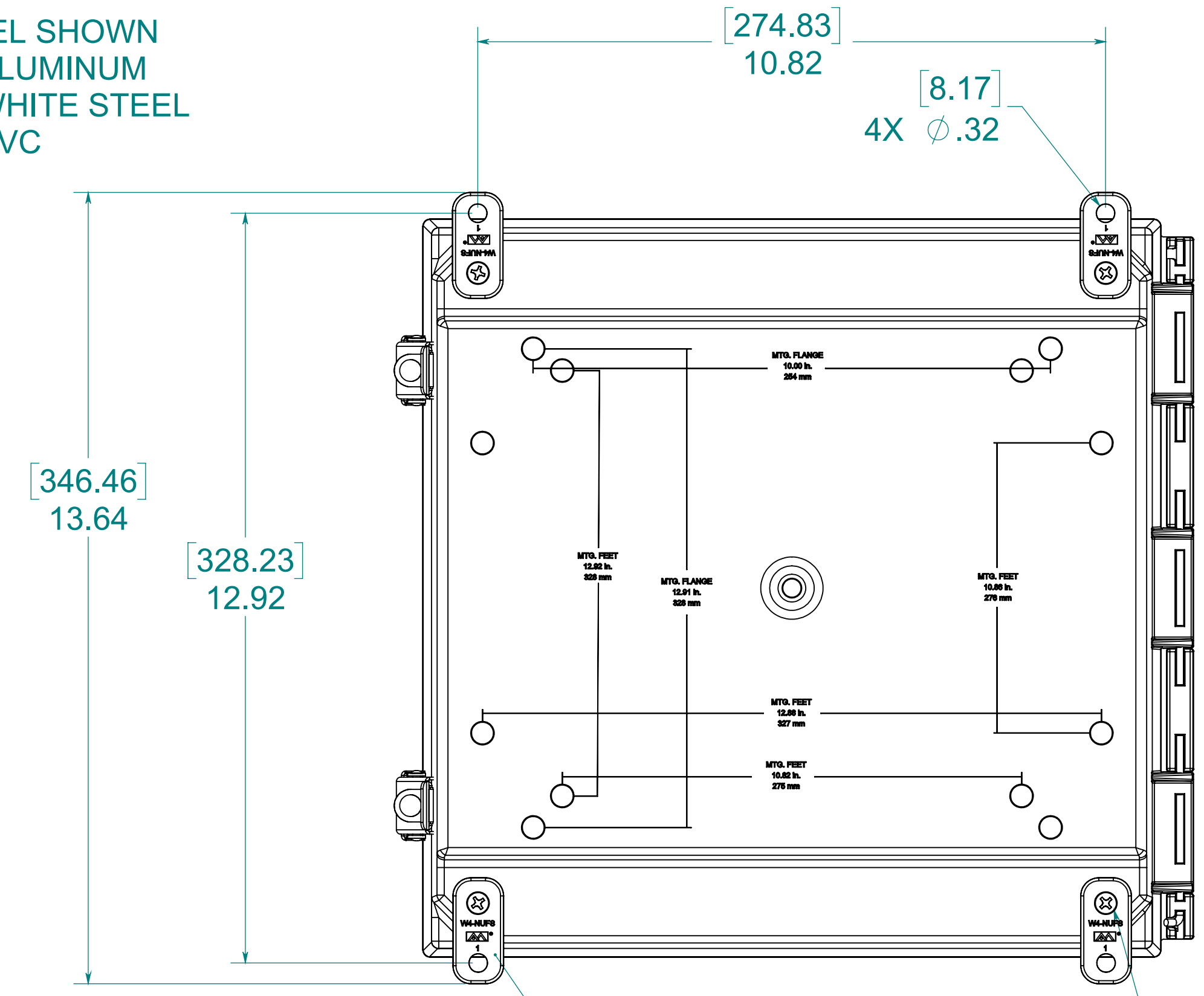

(4X) POLYCARBONATE FEET

(4X) EACH #10-32 BRASS INSERTS AND 316 STAINLESS STEEL FEET SCREWS

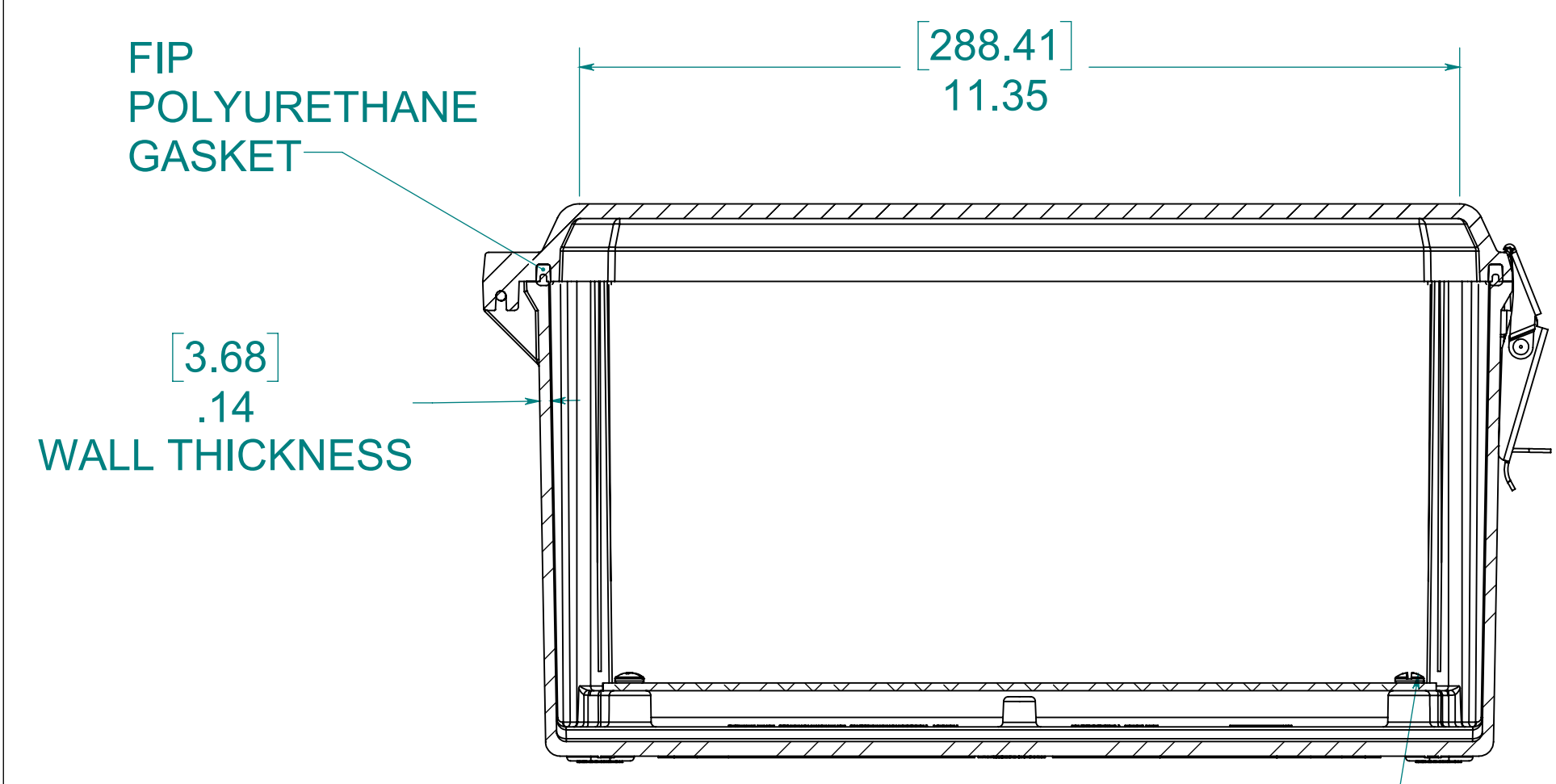

SECTION B-B

(4X) EACH #10-32 BRASS INSERTS AND PLATED CARBON STEEL SCREWS

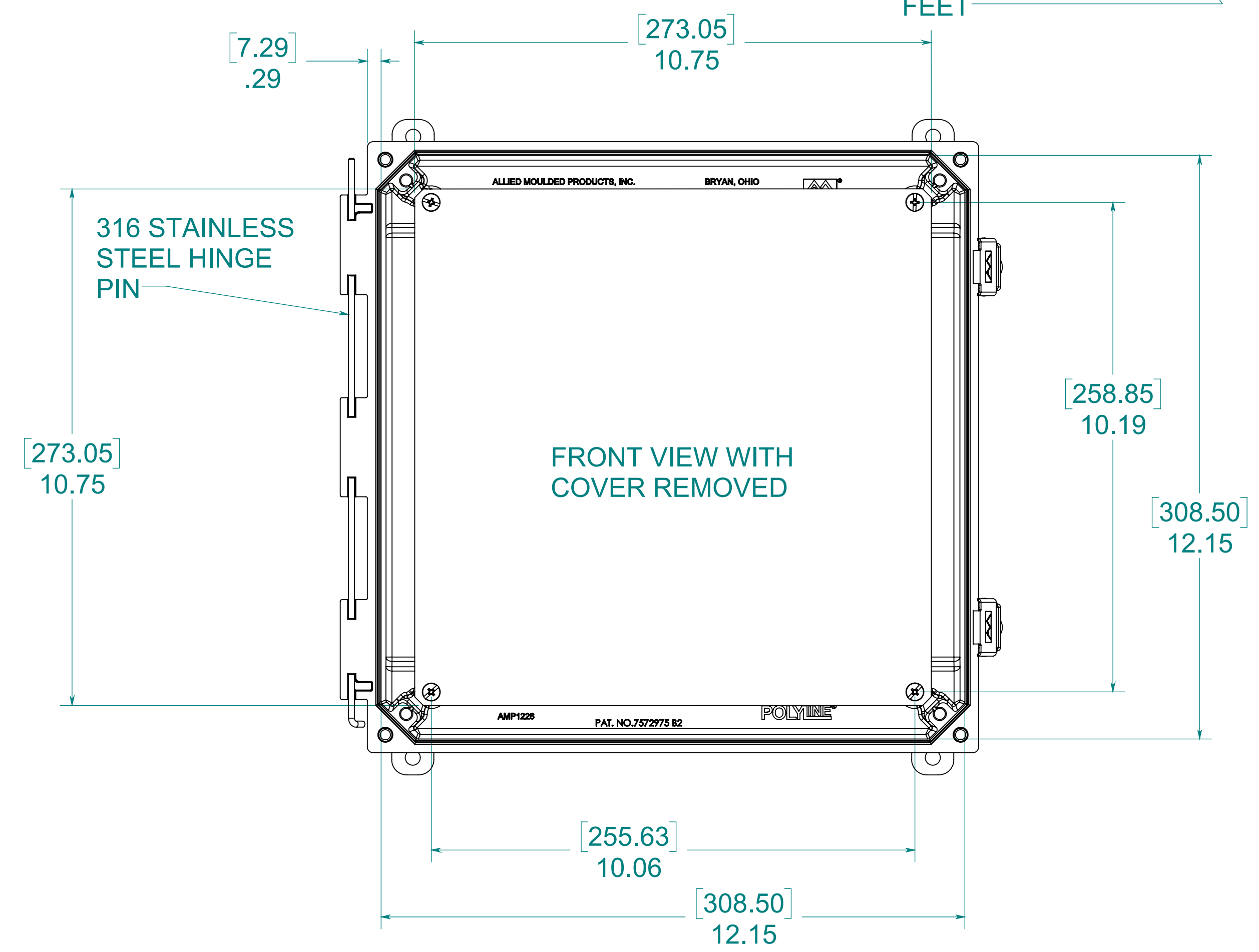

FRONT VIEW WITH COVER REMOVED

MATERIAL:
 BOX- INJECTED POLYCARBONATE
 STANDARD COVER- INJECTED POLYCARBONATE
 CLEAR COVER- INJECTED POLYCARBONATE

NOTE:
 1. DATA SUBJECT TO CHANGE WITHOUT NOTICE



CONFIDENTIAL
 THIS MATERIAL IS OWNED BY THE ALLIED MOULDED PRODUCTS COMPANY, IS DISCLOSED IN CONFIDENCE, AND IS NOT TO BE REPRODUCED OR DISTRIBUTED WITHOUT PRIOR WRITTEN PERMISSION FROM ALLIED MOULDED PRODUCTS.
 © 2018 Allied Moulded Products, Inc. All Rights Reserved

Description
AMP Polyline
 Part No.
AMP1226CCL