

Date	Rev	Description	ECN No.	ISSUE DATE	DR	CK	REL
07/25/2019		INITIAL RELEASE	ECN-302		DJL	LJS	GEL
-	-	-	-	-	-	-	-
-	-	-	-	-	-	-	-

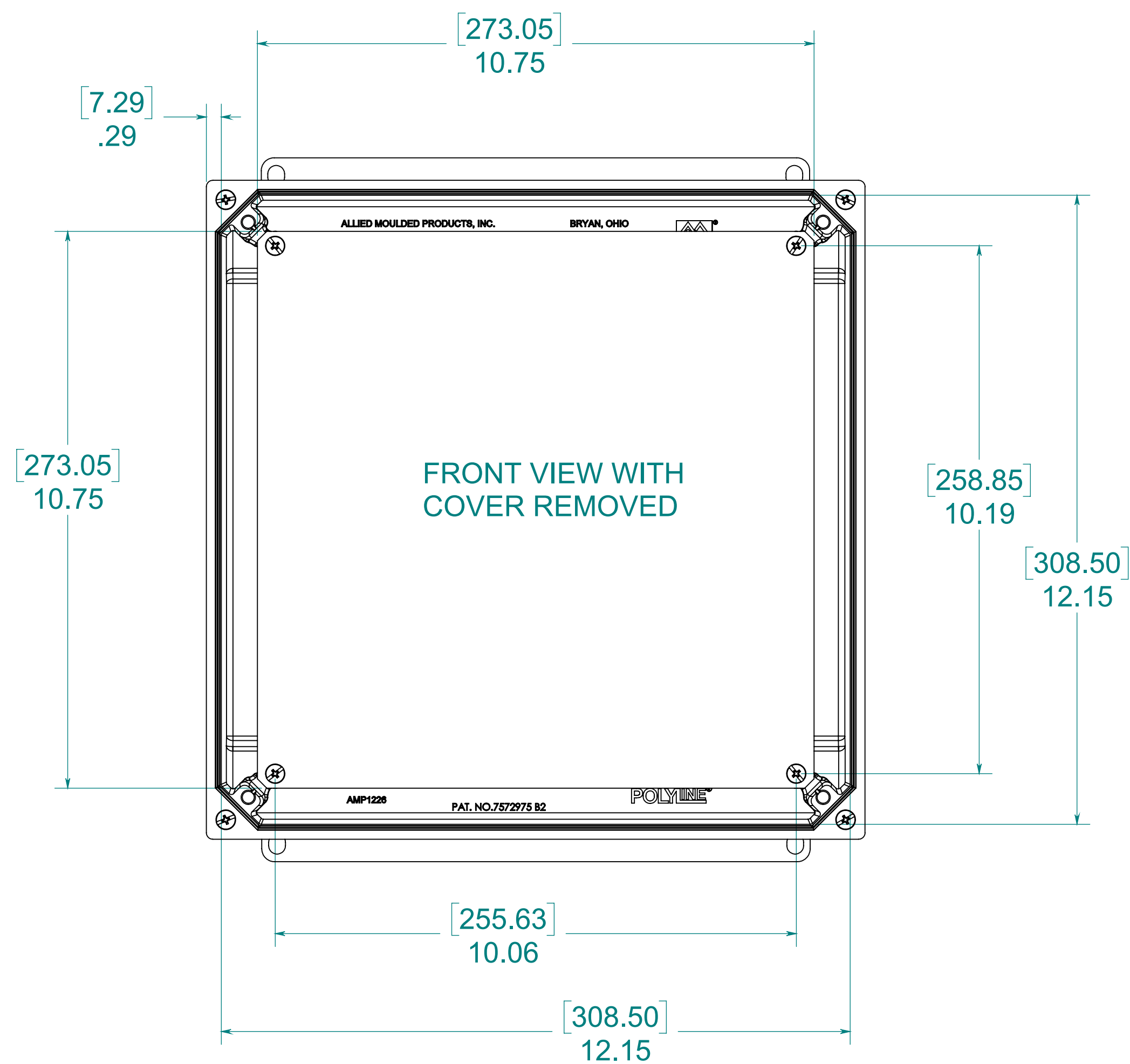

MATERIAL:  
 BOX- INJECTED POLYCARBONATE  
 STANDARD COVER- INJECTED POLYCARBONATE  
 CLEAR COVER- INJECTED POLYCARBONATE

NOTE:  
 1. DATA SUBJECT TO CHANGE WITHOUT NOTICE

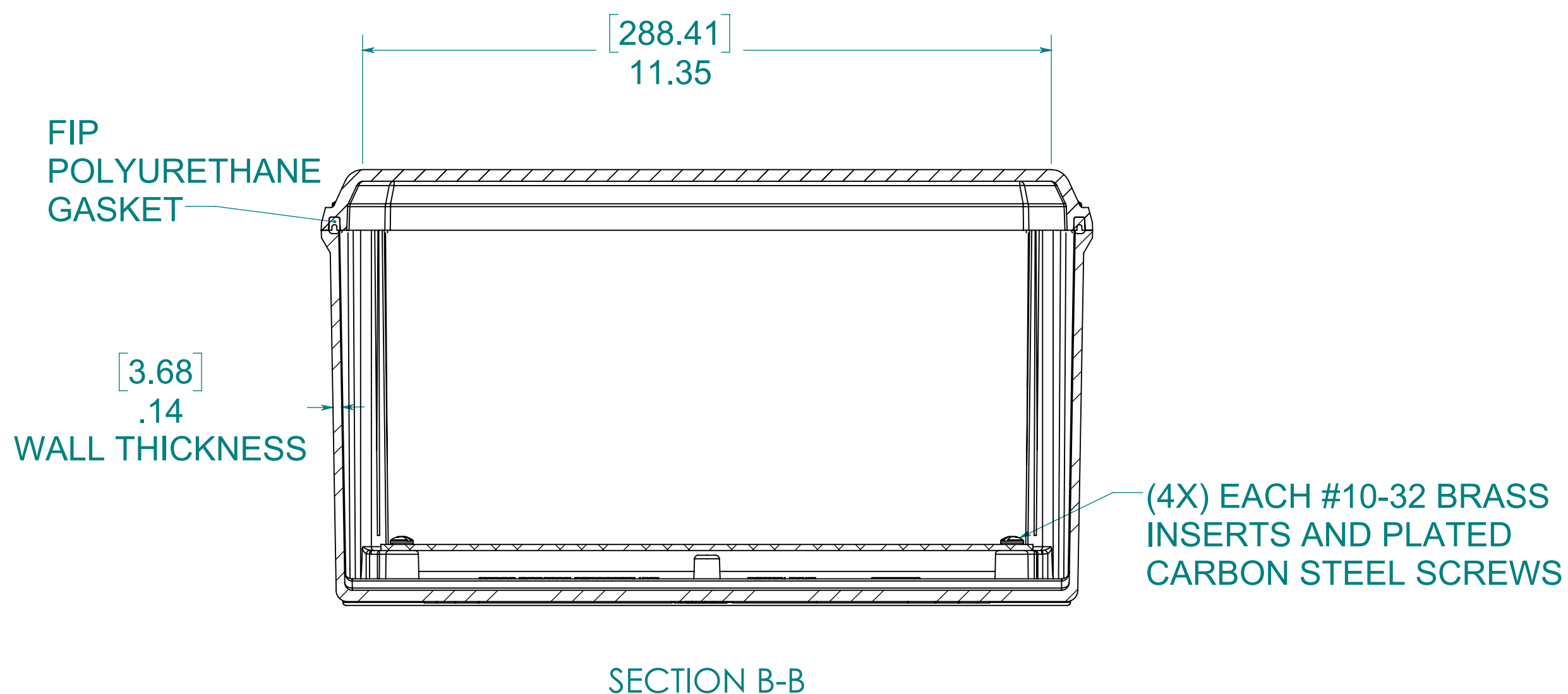
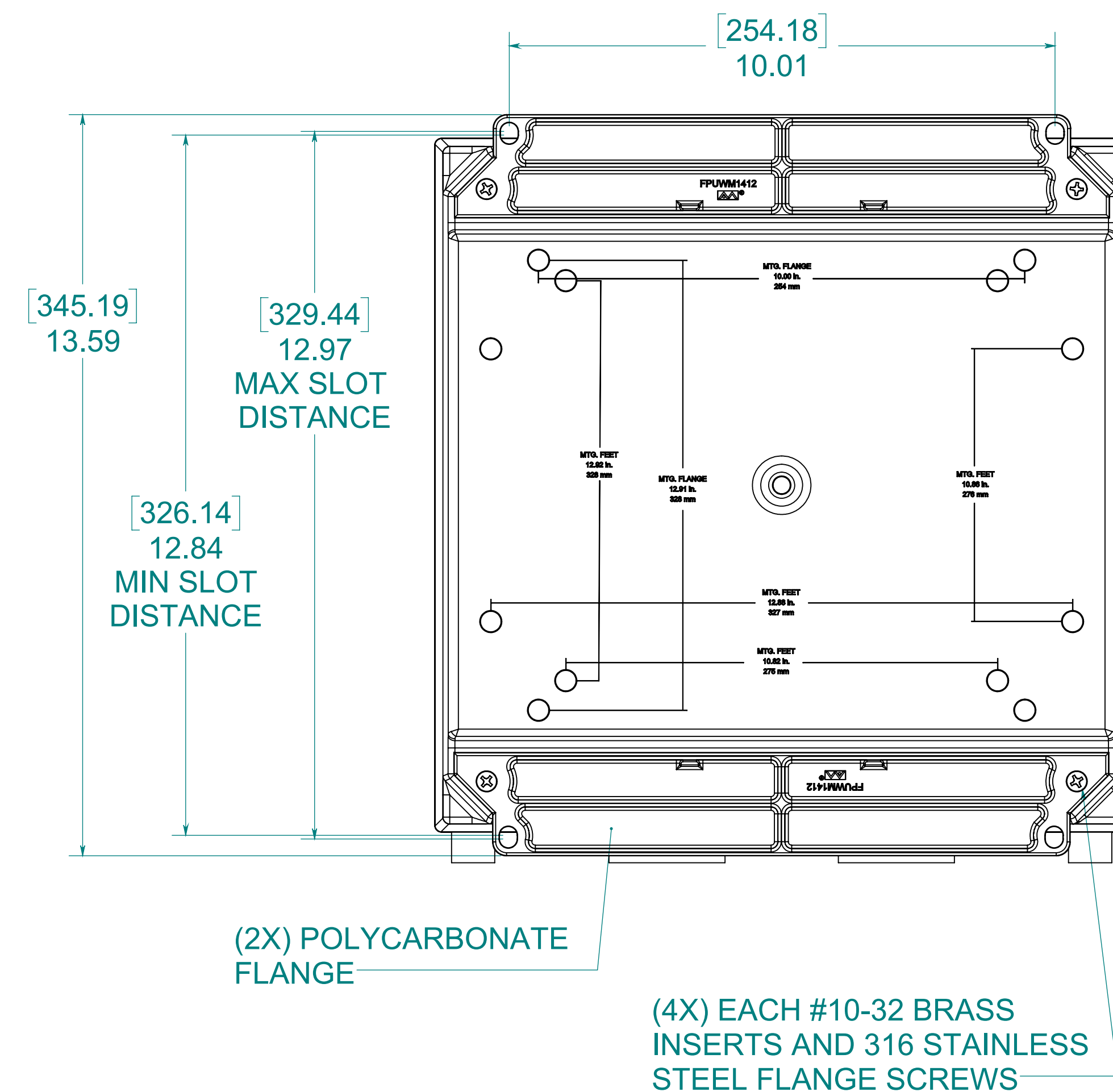
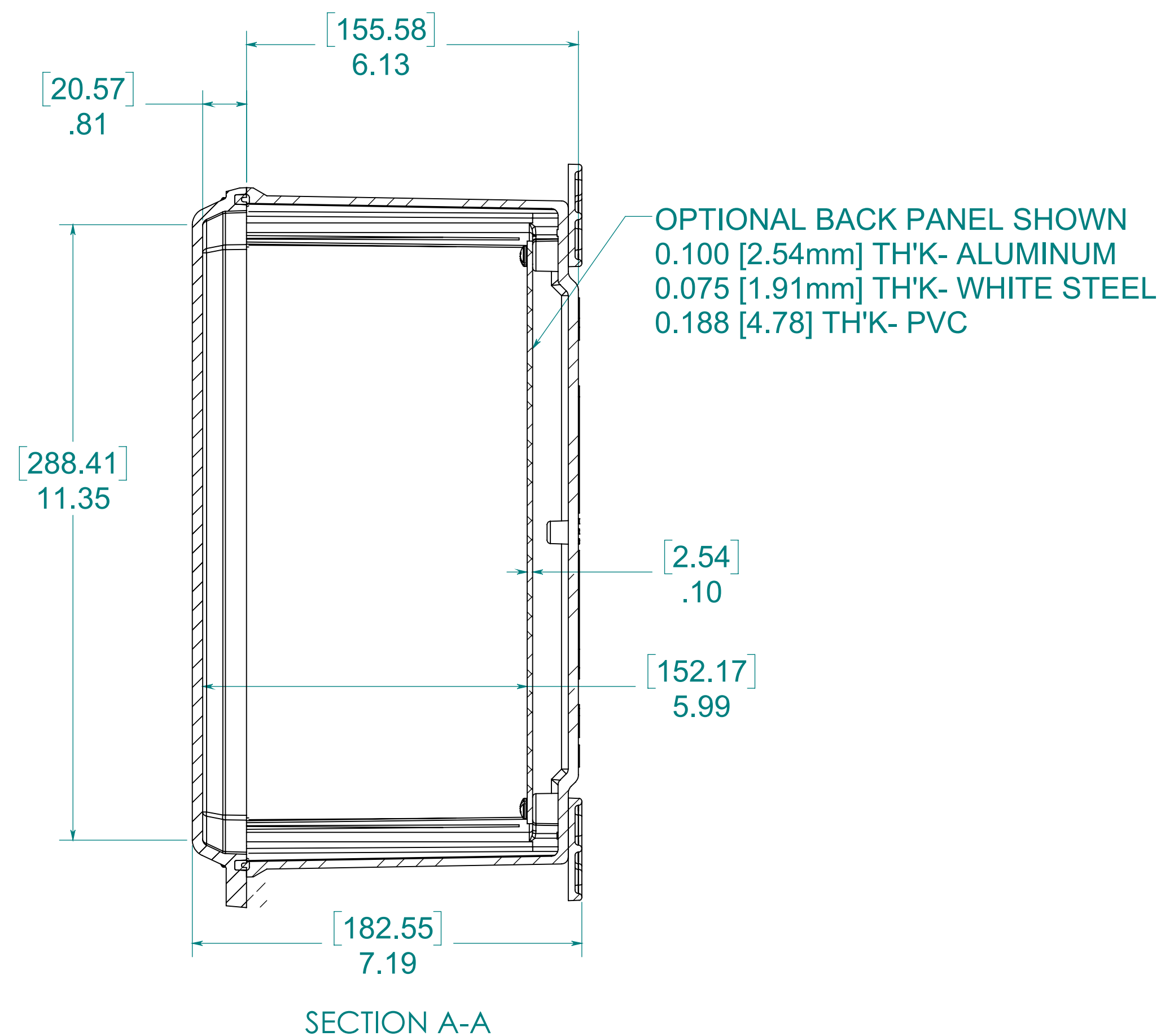
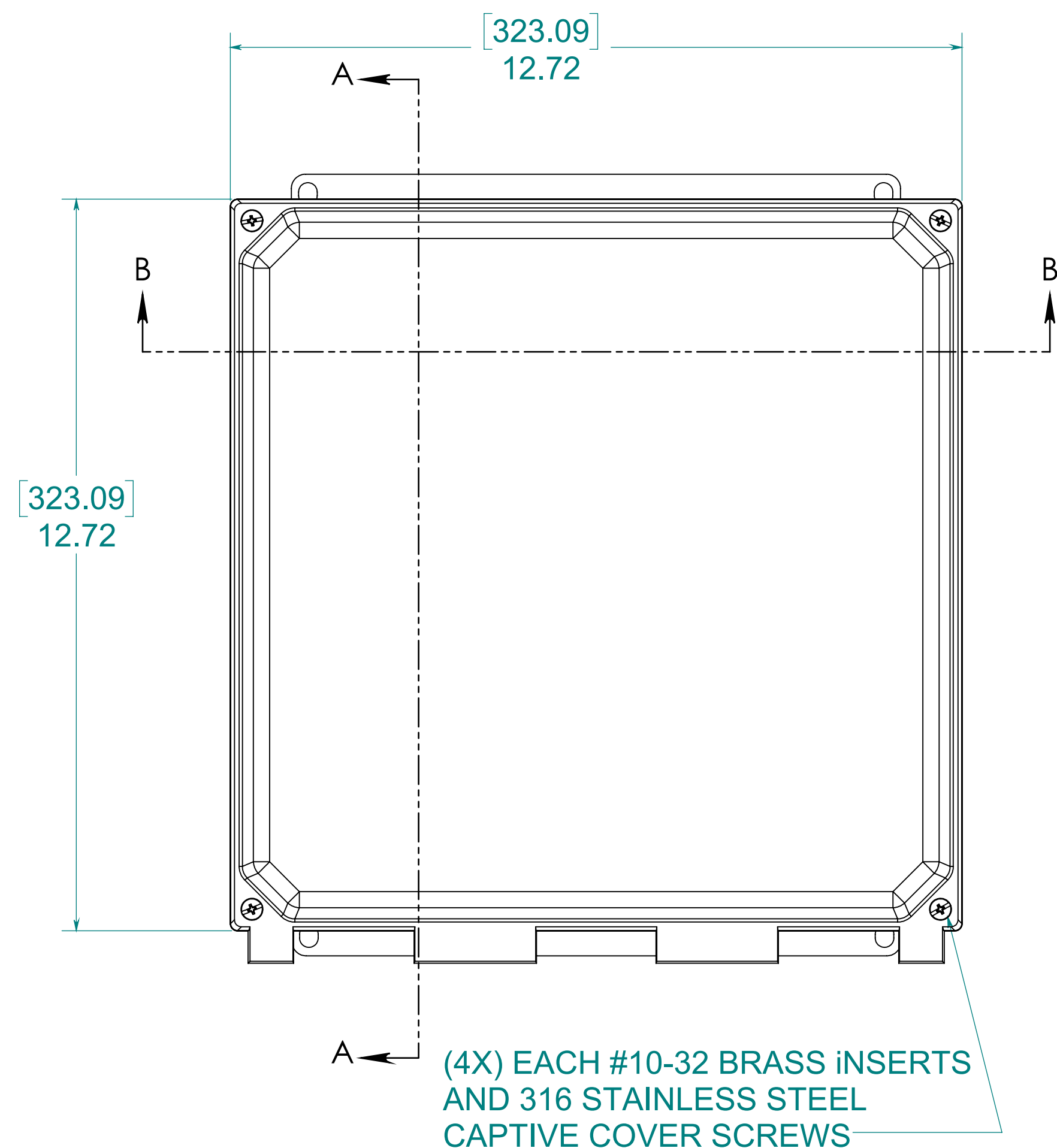

CONFIDENTIAL  
 THIS MATERIAL IS OWNED BY THE ALLIED MOULDED PRODUCTS COMPANY, IS DISCLOSED IN CONFIDENCE, AND IS NOT TO BE REPRODUCED OR DISTRIBUTED WITHOUT PRIOR WRITTEN PERMISSION FROM ALLIED MOULDED PRODUCTS.  
 © 2018 Allied Moulded Products, Inc. All Rights Reserved

Description  
 AMP Polyline  
 Part No.  
 AMP1226F