

OPTIONAL BACK PANEL SHOWN
 0.100 [2.54mm] TH'K - ALUMINUM
 0.075 [1.91mm] TH'K - WHITE STEEL
 0.188 [4.78mm] TH'K - PVC

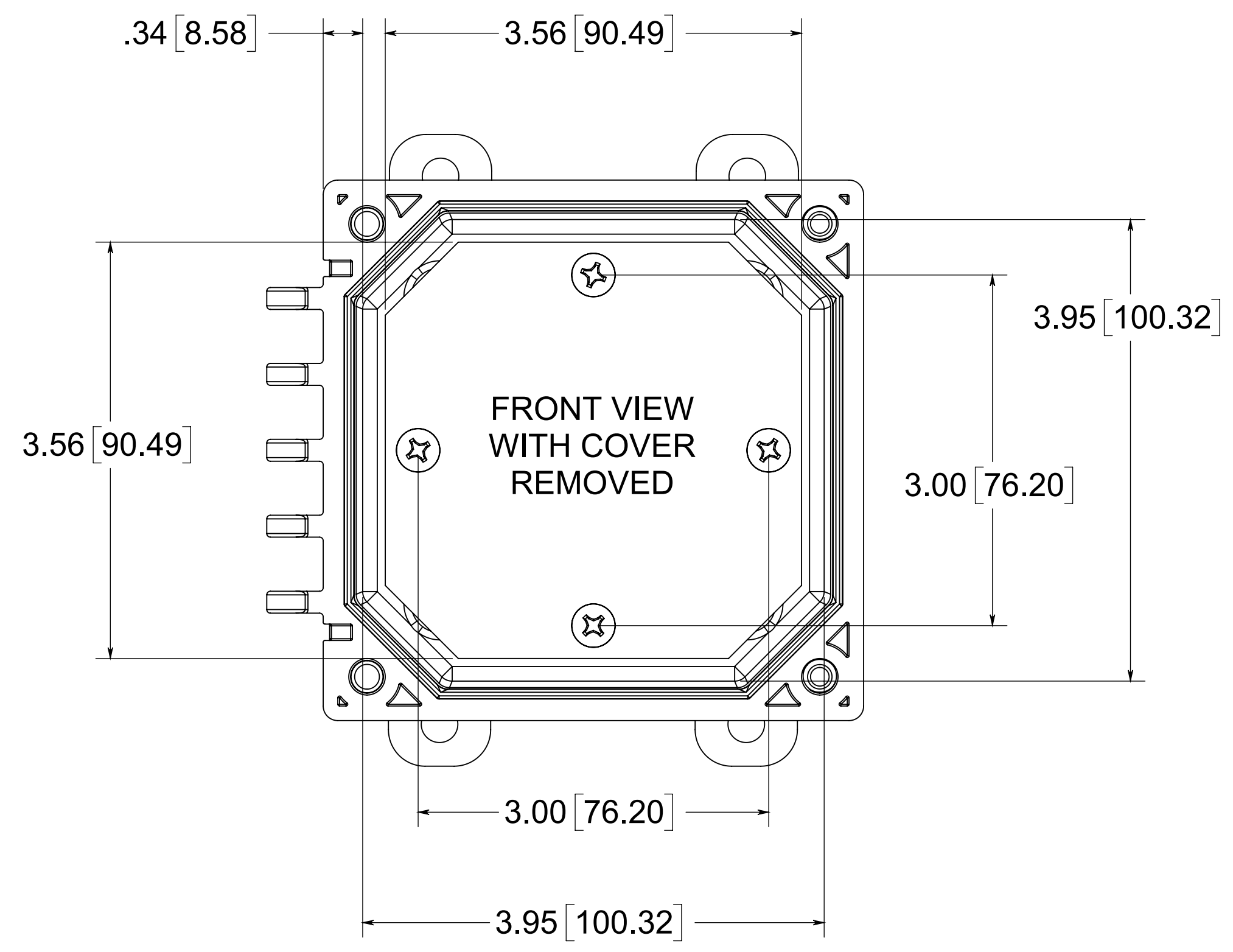

NOTE:
 1. DATA SUBJECT TO CHANGE WITHOUT NOTICE

MATERIAL:
 BOX - INJECTED POLYCARBONATE
 STANDARD COVER - INJECTED POLYCARBONATE
 CLEAR COVER - INJECTED POLYCARBONATE

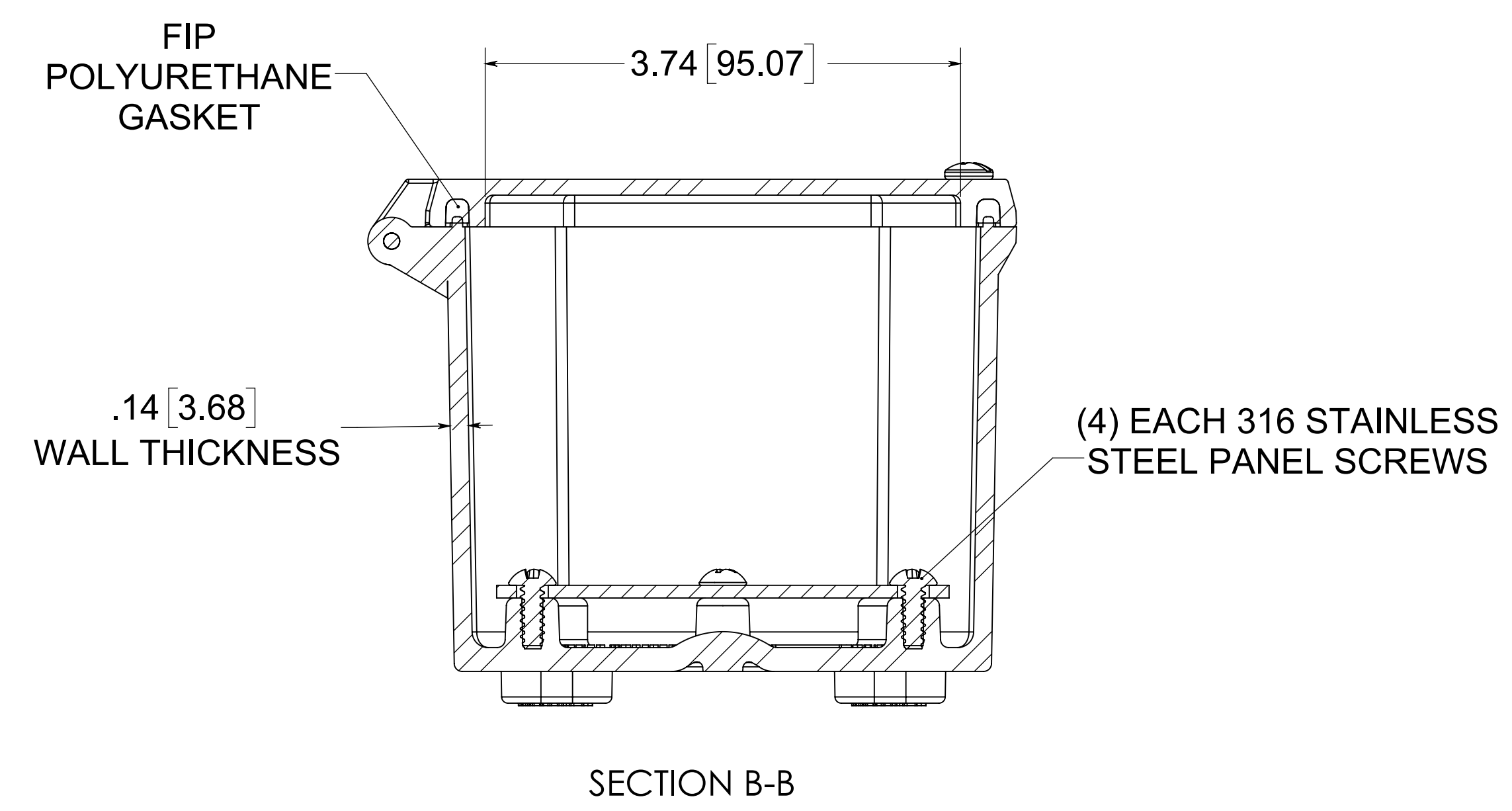
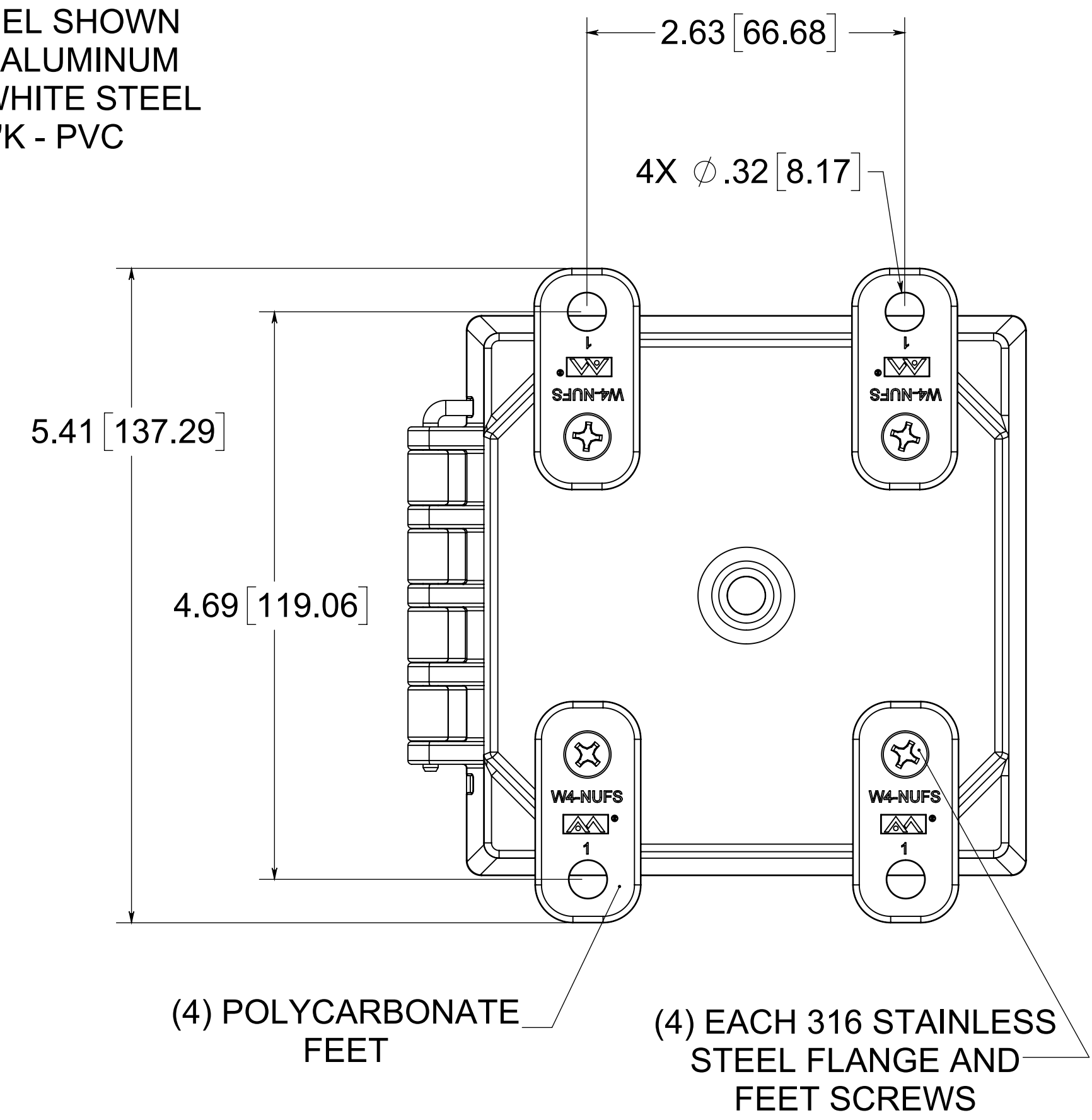
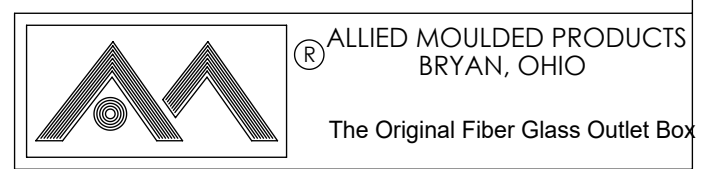

CONFIDENTIAL
 THIS MATERIAL IS OWNED BY THE ALLIED MOULDED PRODUCTS COMPANY, IS DISCLOSED IN CONFIDENCE, AND IS NOT TO BE REPRODUCED OR DISTRIBUTED WITHOUT PRIOR WRITTEN PERMISSION FROM ALLIED MOULDED PRODUCTS.
 © 2018 Allied Moulded Products, Inc.
 All Rights Reserved

Description
AMP Polyline
 Part No.
AMP443H