

(4X) EACH # 10-32 BRASS INSERTS AND 316 STAINLESS CATIVE COVER SCREWS

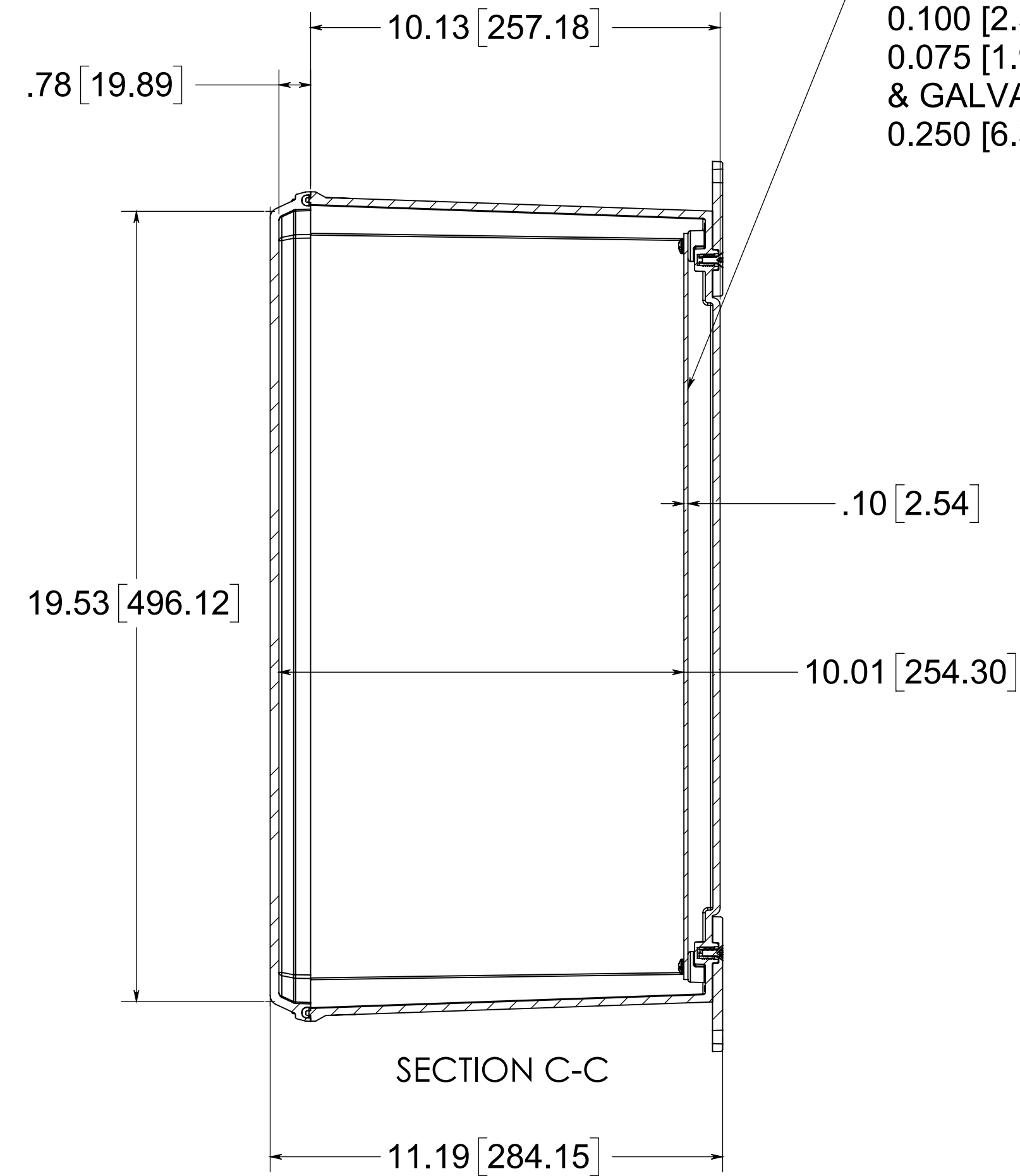

SECTION C-C

OPTIONAL BACK PANEL
 0.100 [2.54] TH'K - ALUMINUM
 0.075 [1.91] TH'K - WHITE STEEL & GALVANNEALED
 0.250 [6.35] TH'K - FIBERGLASS

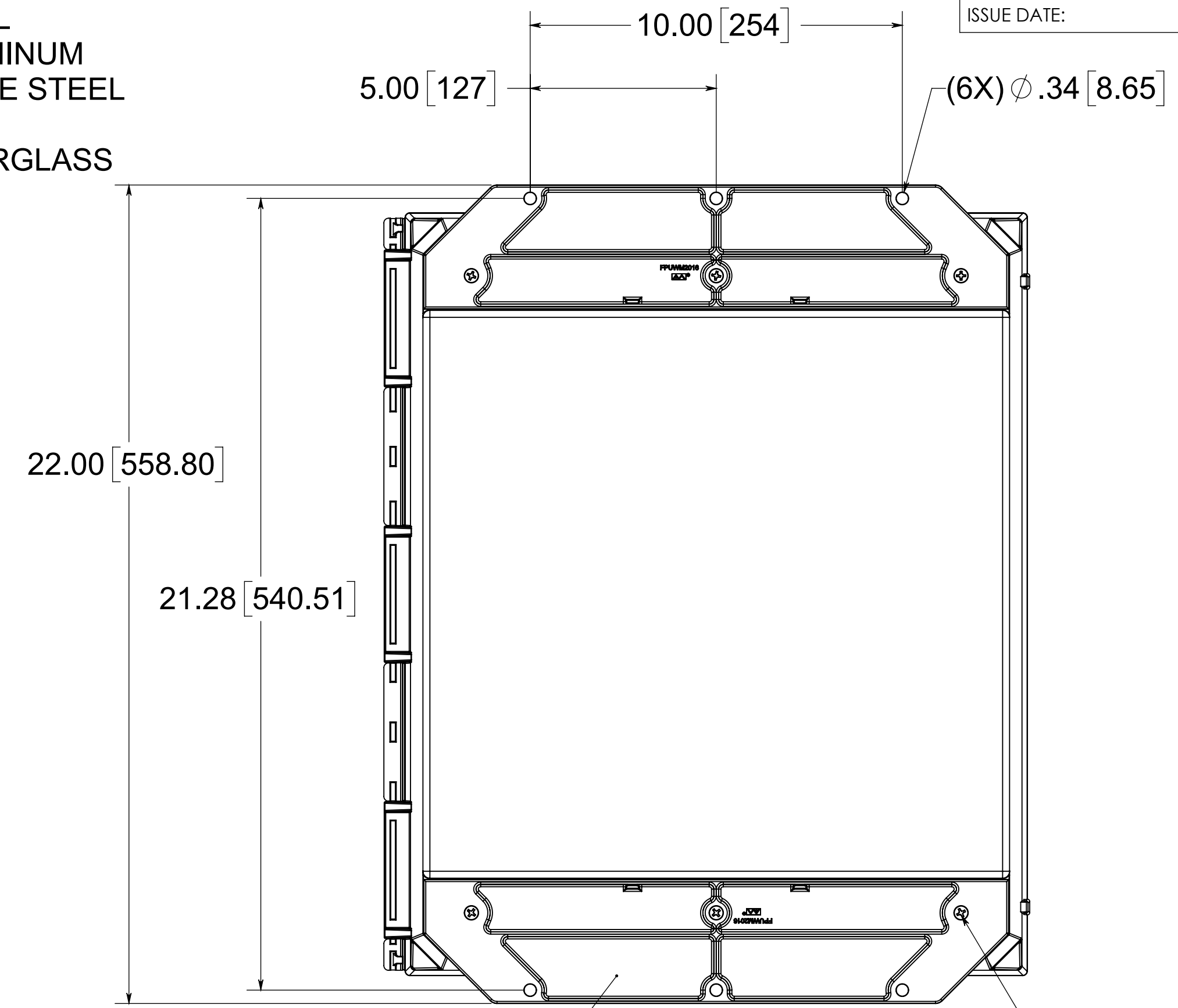

(2X) POLYCARBONATE FLANGES

(6X) EACH #10-32 BRASS INSERTS AND 316 STAINLESS STEEL FLANGE AND FEET SCREWS

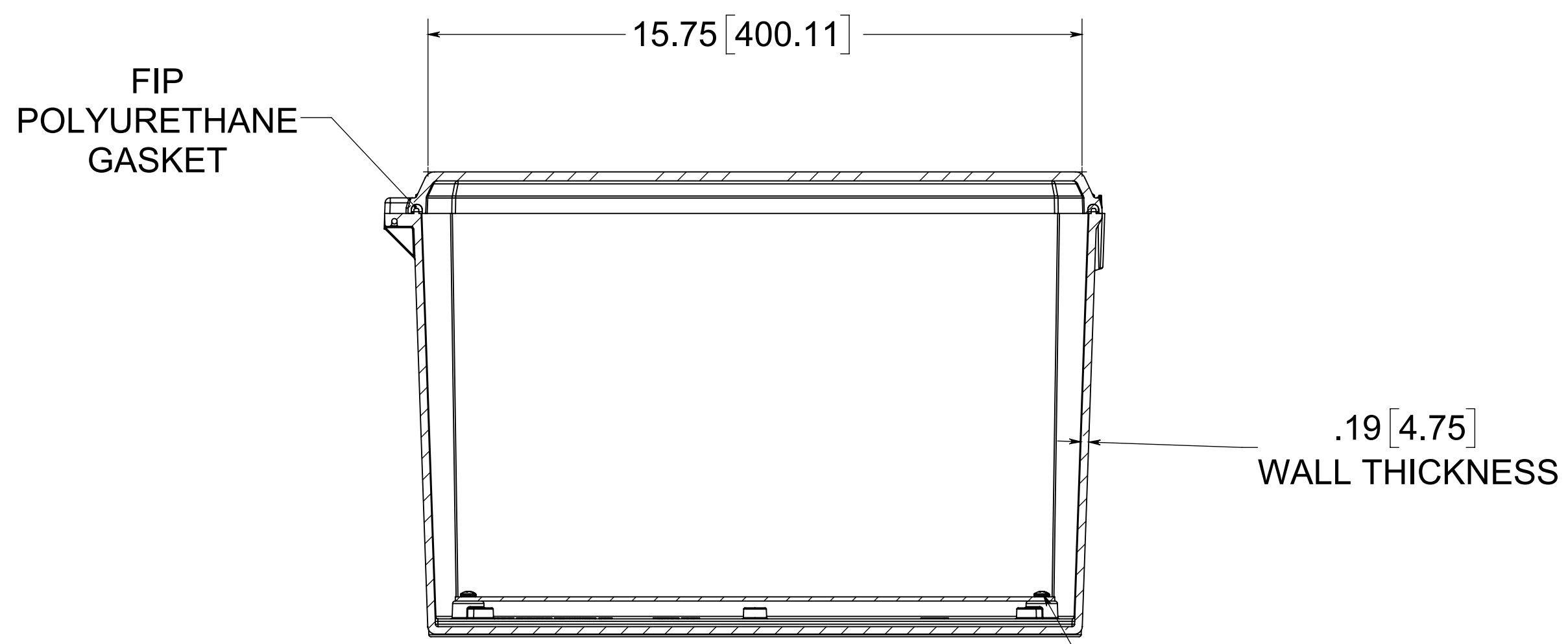

SECTION D-D

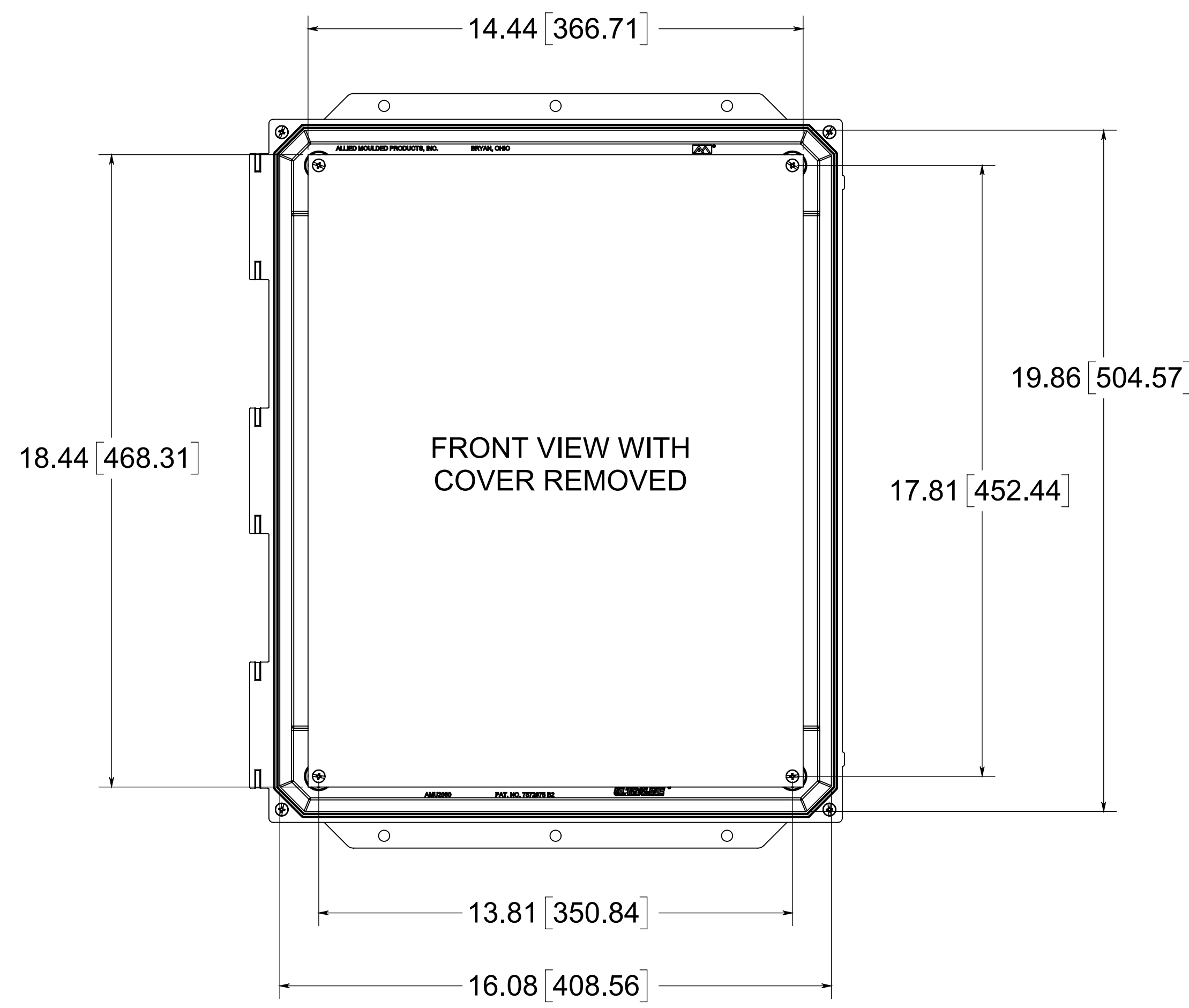

FRONT VIEW WITH COVER REMOVED

NOTE:
 1. DATA SUBJECT TO CHANGE

MATERIAL:
 BOX: INJECTION MOLDED POLYCARBONATE
 STANDARD COVER: INJECTION MOLDED POLYCARBONATE
 CLEAR COVER: INJECTION MOLDED POLYCARBONATE

ALLIED MOULDED PRODUCTS
 BRYAN, OHIO
 The Original Fiber Glass Outlet Box

AMU Ultraline

Part No. AMU2060CCF

CONFIDENTIAL
 THIS MATERIAL IS OWNED BY THE ALLIED MOULDED PRODUCTS COMPANY, IS DISCLOSED IN CONFIDENCE, AND IS NOT TO BE REPRODUCED OR DISTRIBUTED WITHOUT PRIOR WRITTEN PERMISSION FROM ALLIED MOULDED PRODUCTS.
 © Allied Moulded Products, Inc. All Rights Reserved