

(2X) EACH #10-32 BRASS INSERTS AND 316 STAINLESS STEEL CAPTIVE COVER SCREWS

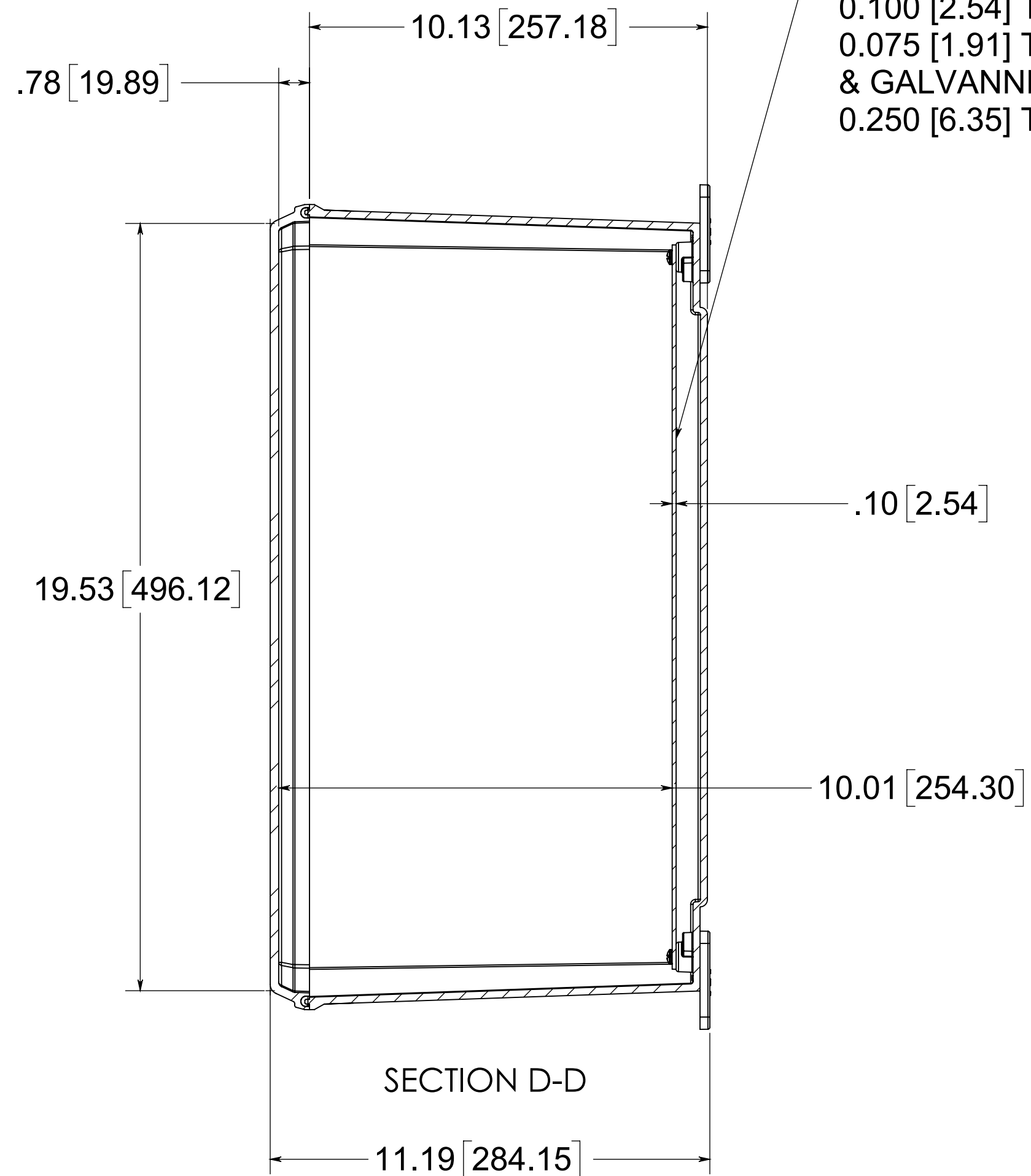

SECTION D-D

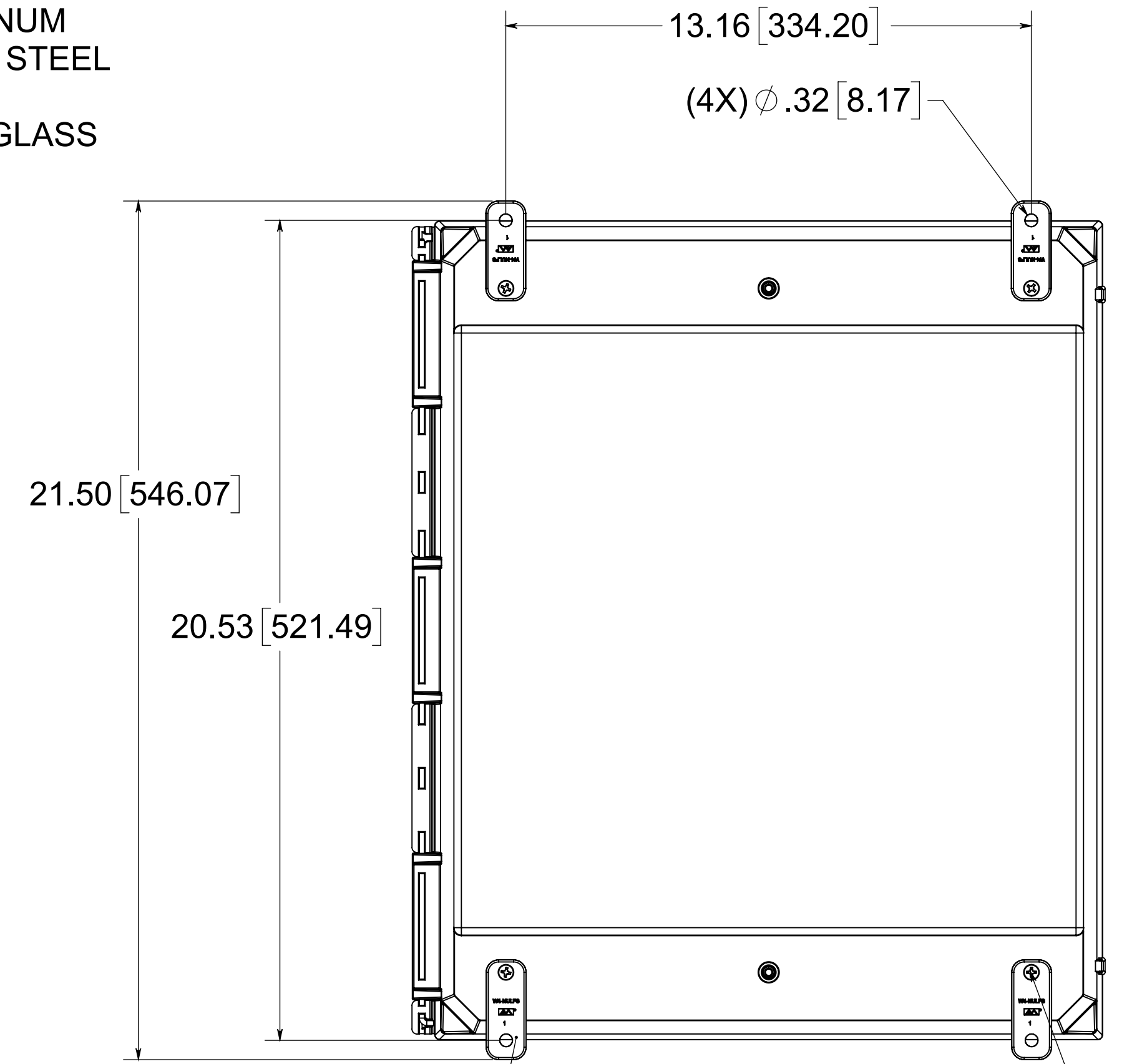

(4X) POLYCARBONATE FEET

(4X) EACH #10-32 BRASS INSERTS AND 316 STAINLESS STEEL FLANGE AND FEET SCREWS

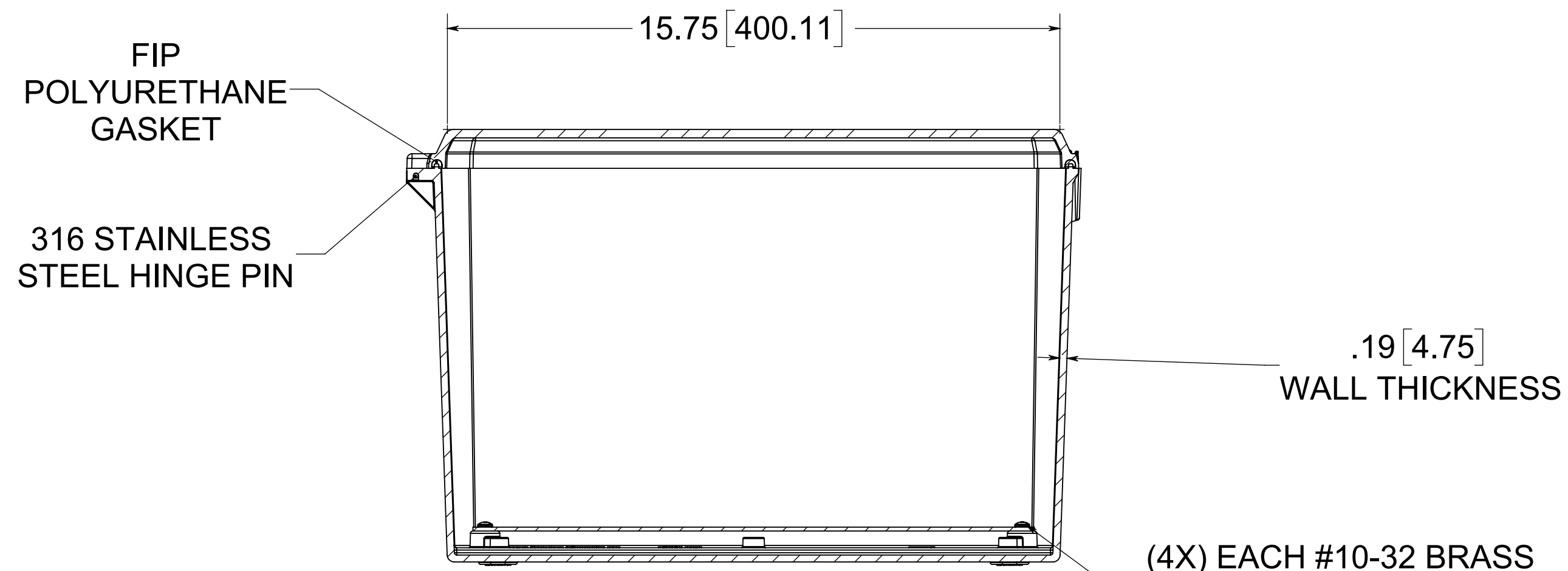

SECTION C-C

(4X) EACH #10-32 BRASS INSERT AND PLATED CARBON STEEL SCREWS

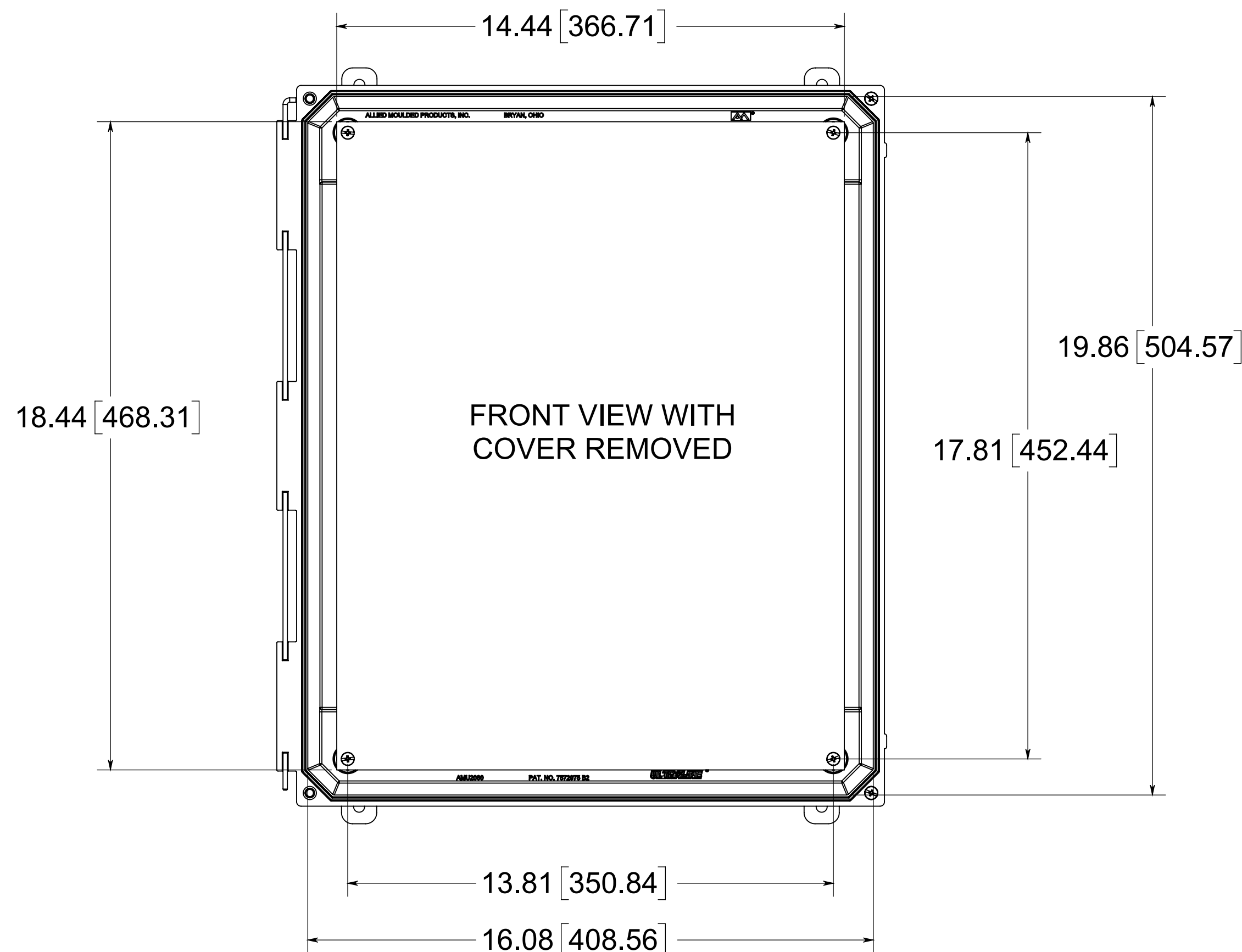

FRONT VIEW WITH COVER REMOVED

MATERIAL:
 BOX: INJECTION MOLDED POLYCARBONATE
 STANDARD COVER: INJECTION MOLDED POLYCARBONATE
 CLEAR COVER: INJECTION MOLDED POLYCARBONATE

NOTE:
 1. DATA SUBJECT TO CHANGE

CONFIDENTIAL
 THIS MATERIAL IS OWNED BY THE ALLIED MOULDED PRODUCTS COMPANY, IS DISCLOSED IN CONFIDENCE, AND IS NOT TO BE REPRODUCED OR DISTRIBUTED WITHOUT PRIOR WRITTEN PERMISSION FROM ALLIED MOULDED PRODUCTS.
 © Allied Moulded Products, Inc. All Rights Reserved

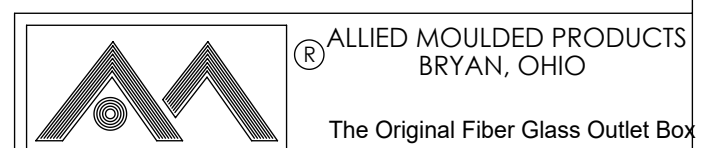

Description
AMU Ultraline
 Part No.
AMU2060CCH