

(4X) EACH #10-32 BRASS INSERTS AND 316 STAINLESS STEEL CAPTIVE COVER SCREWS WITH RETAINING O-RING

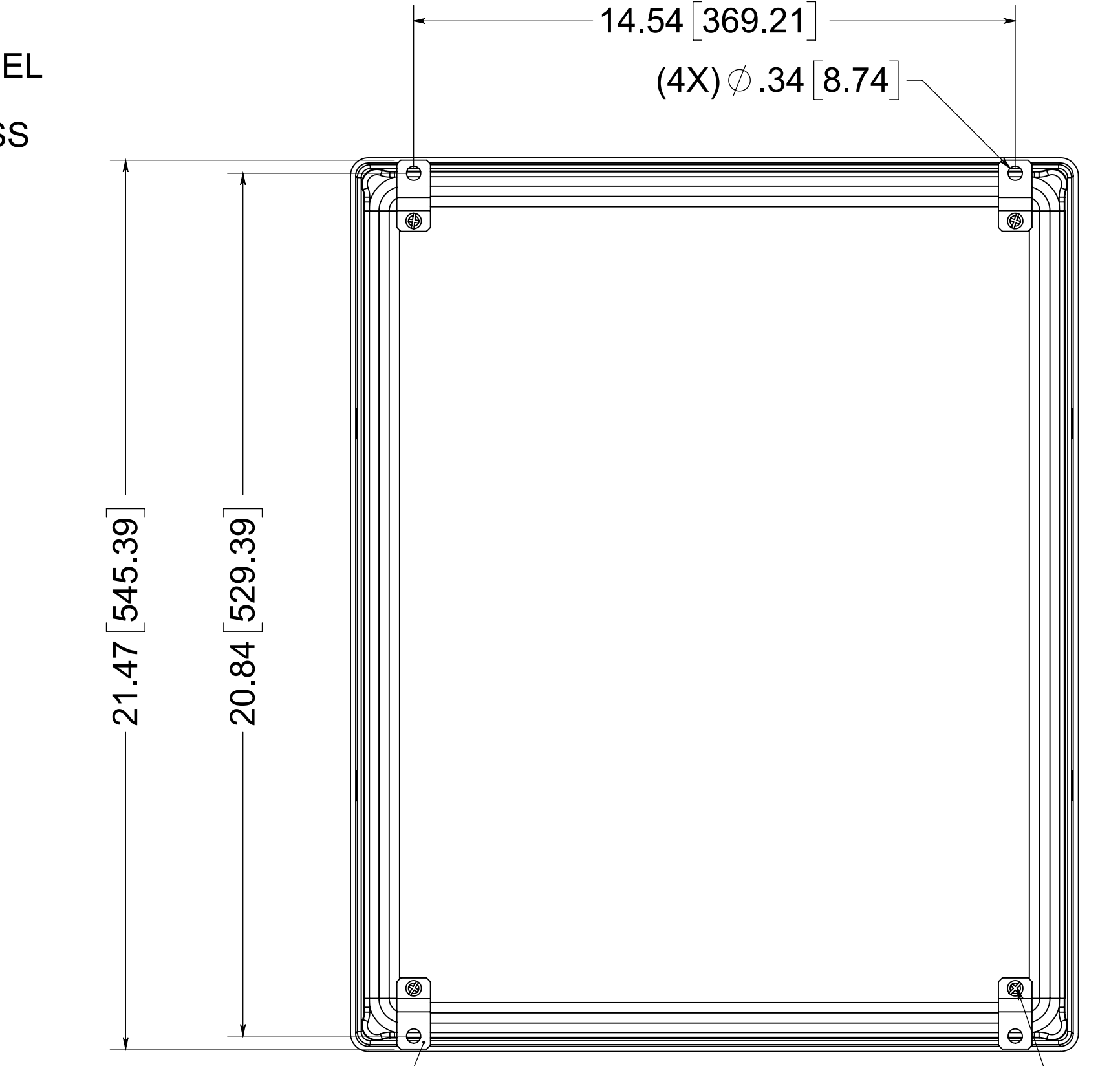

(4X) 316 STAINLESS STEEL FEET
(4X) EACH #10-32 BRASS INSERTS, AND 316 STAINLESS STEEL FEET SCREWS

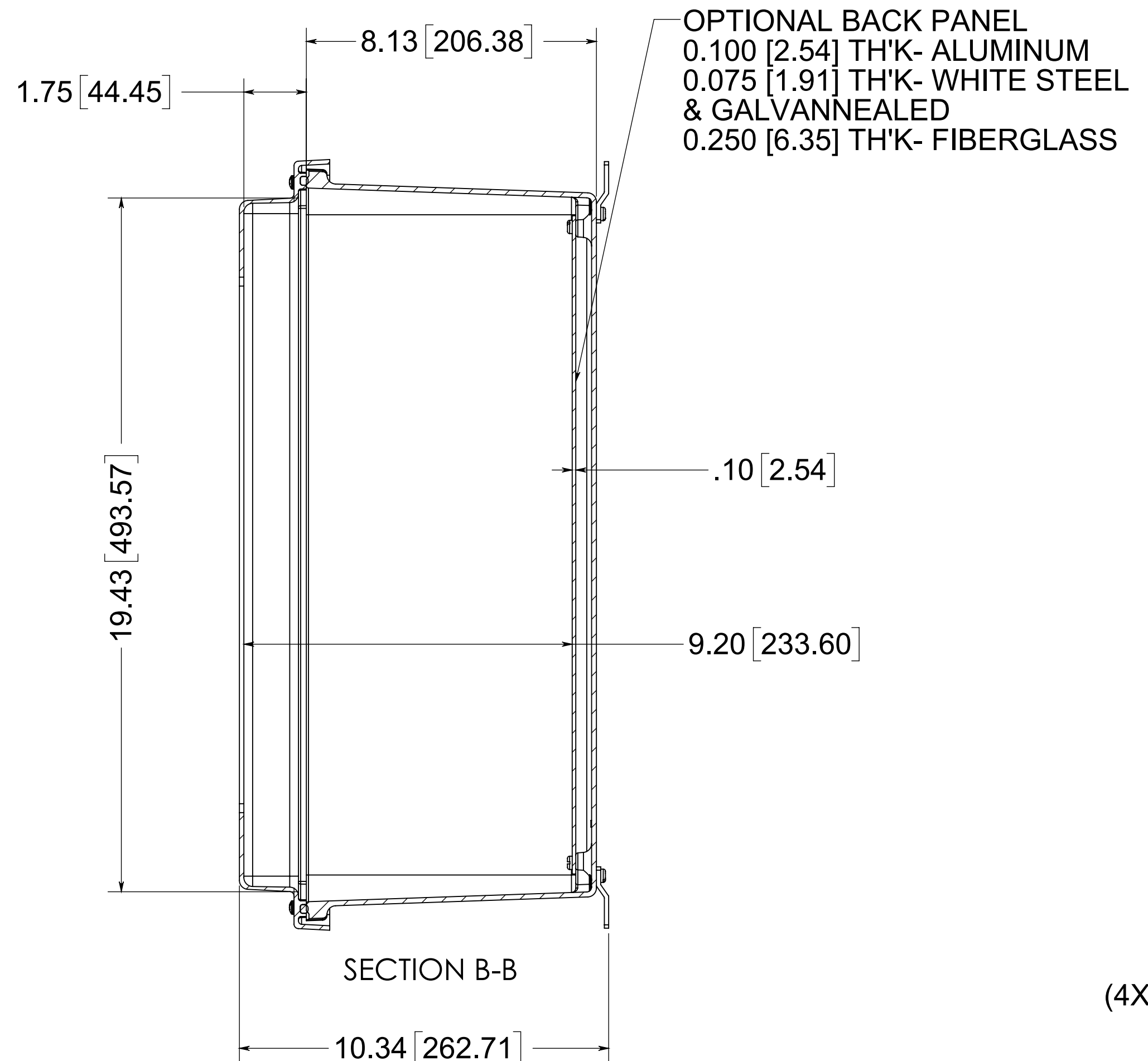
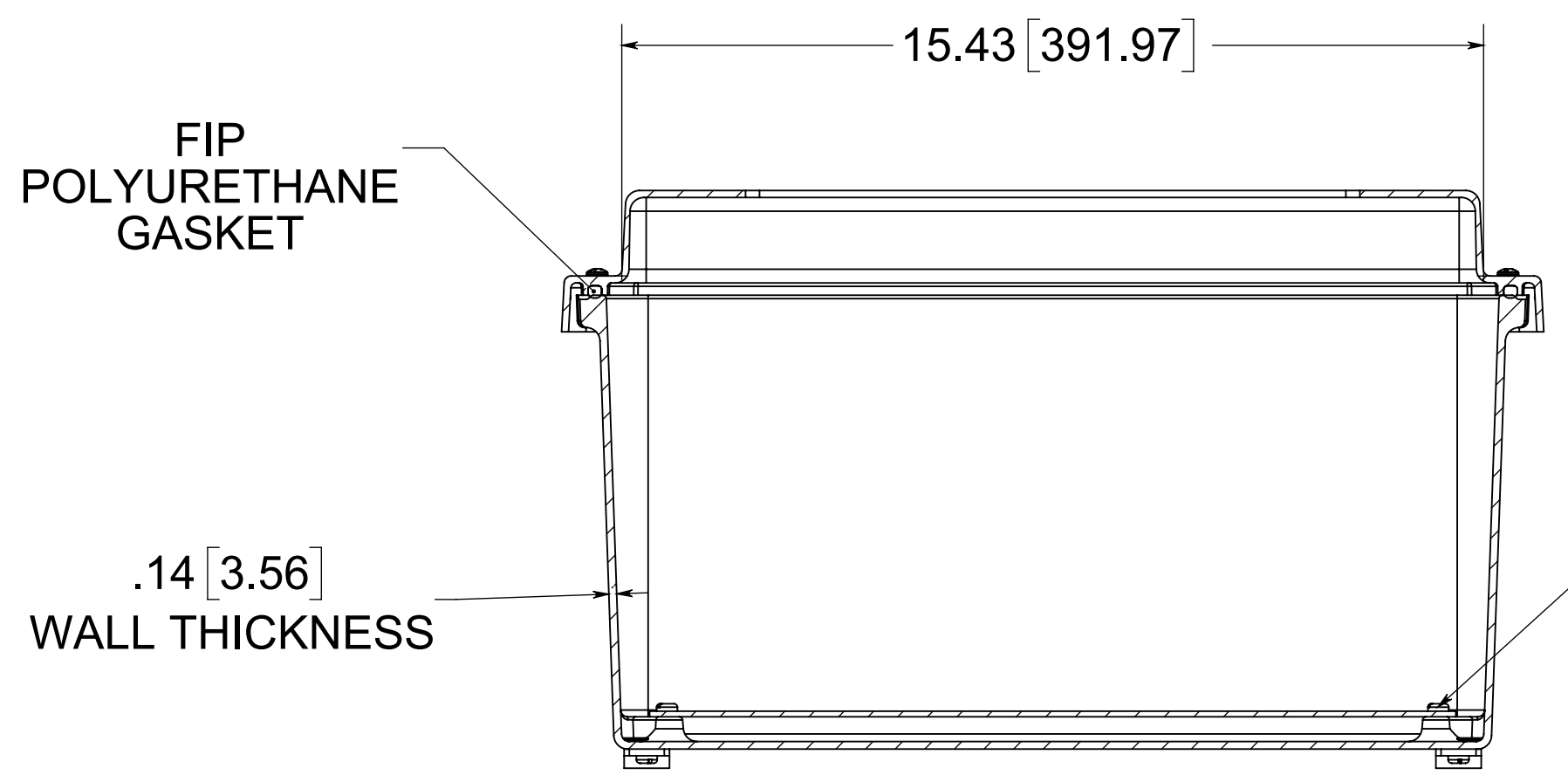

SECTION A-A

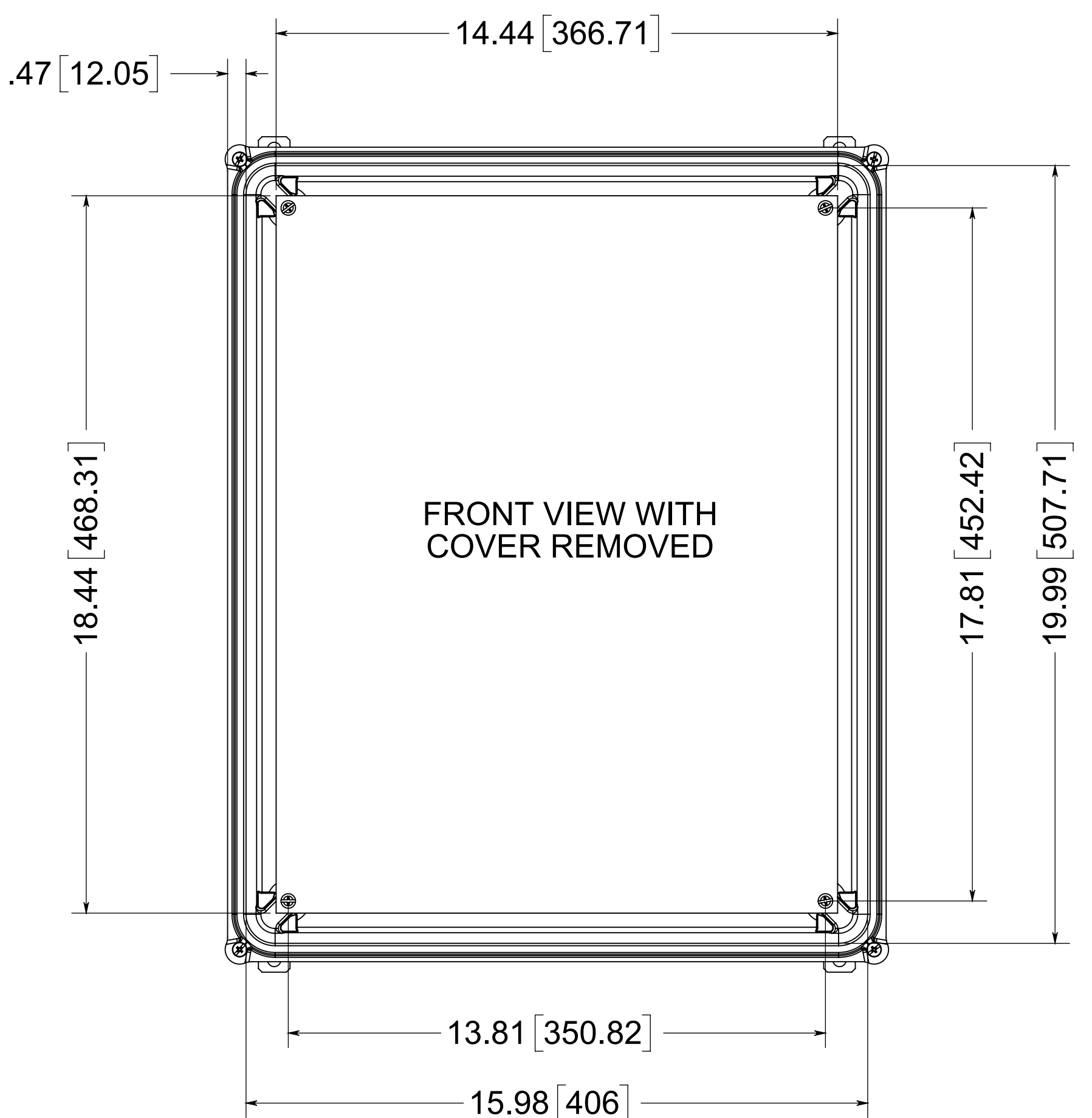

FRONT VIEW WITH COVER REMOVED

MATERIAL:
BOX-COMPRESSION MOLDED FIBERGLASS REINFORCED POLYESTER
COVER- COMPRESSION MOLDED FIBERGLASS REINFORCED POLYESTER
WINDOW- POLYCARBONATE

NOTE:
1. DATA SUBJECT TO CHANGE WITHOUT NOTICE

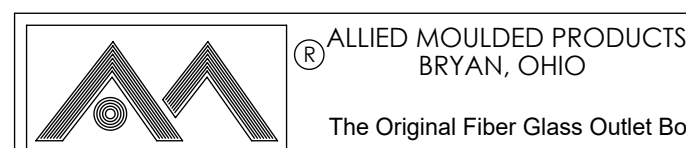

Description
AM Raised Cov
Part No.
AM2068RW

CONFIDENTIAL
THIS MATERIAL IS OWNED BY THE ALLIED MOULDED PRODUCTS COMPANY, IS DISCLOSED IN CONFIDENCE, AND IS NOT TO BE REPRODUCED OR DISTRIBUTED WITHOUT PRIOR WRITTEN PERMISSION FROM ALLIED MOULDED PRODUCTS.