

DATE	SYM.	DESCRIPTION	DR	CK	REL

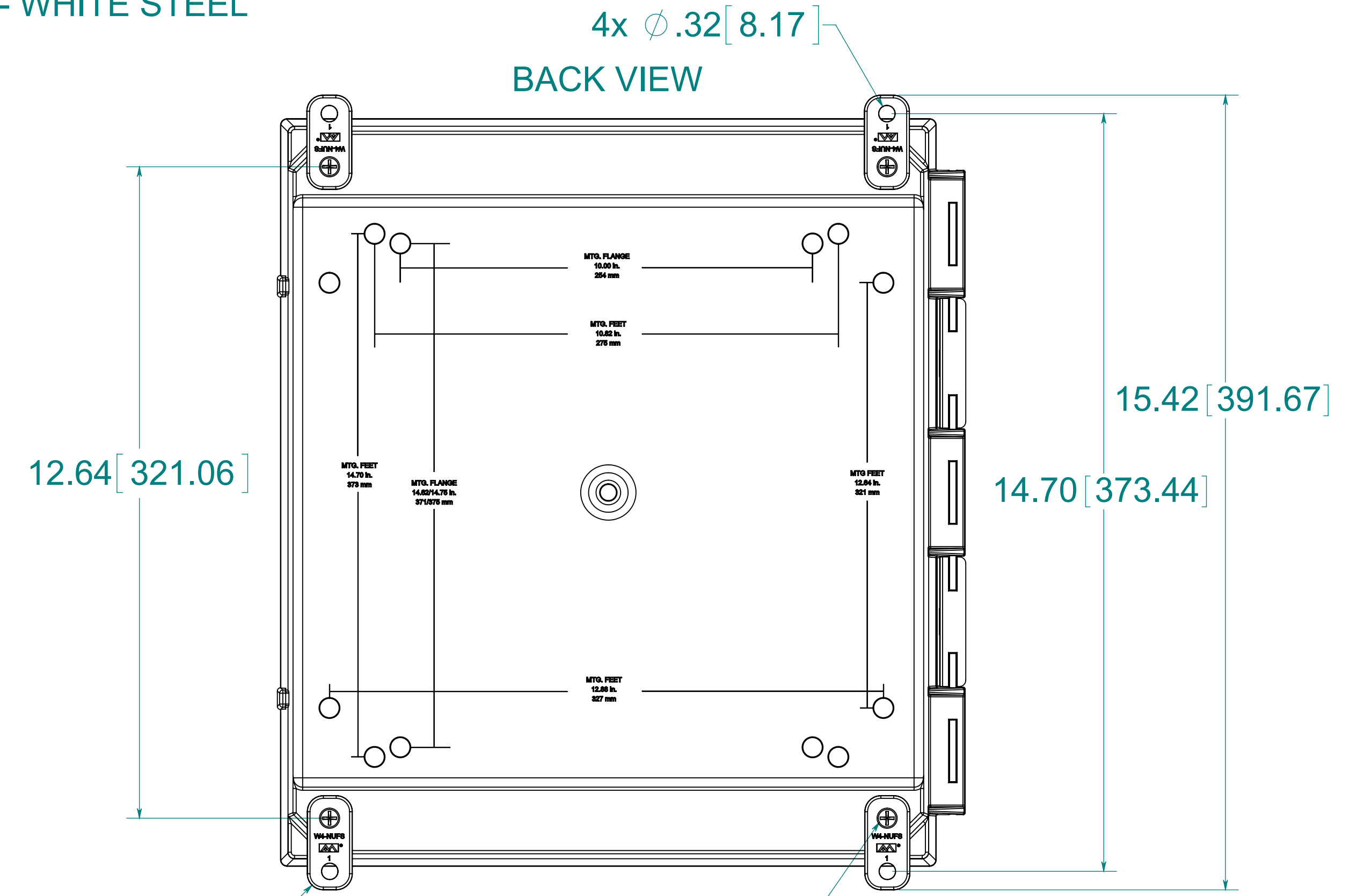
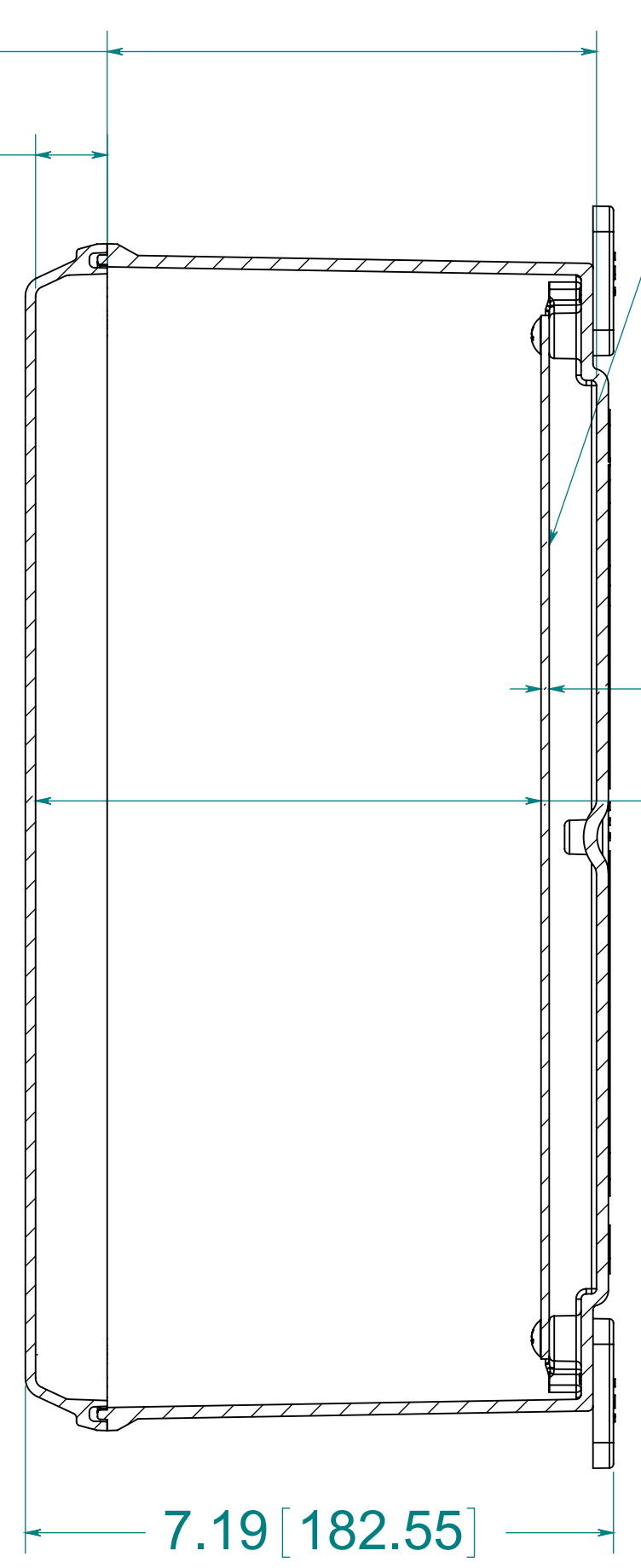
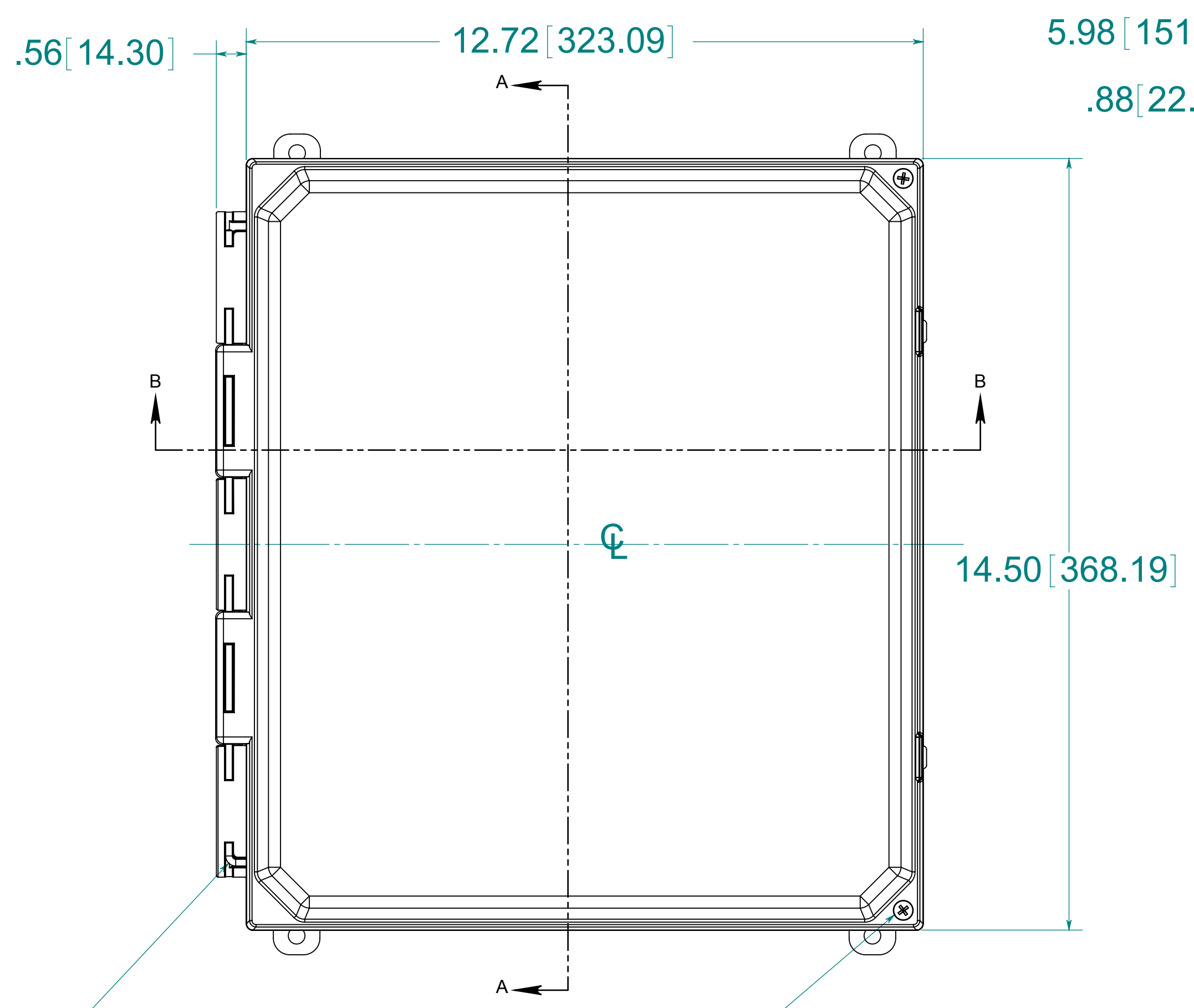

STAINLESS STEEL HINGE PIN

(2) EACH #10-32 BRASS INSERTS AND STAINLESS STEEL CAPTIVE COVER SCREWS WITH RETAINING O-RING

(4) POLYCARBONATE FEET

(4) EACH #10-32 BRASS INSERTS, AND STAINLESS STEEL FLANGE AND FEET SCREWS

CLOSED CELL NEOPRENE GASKET

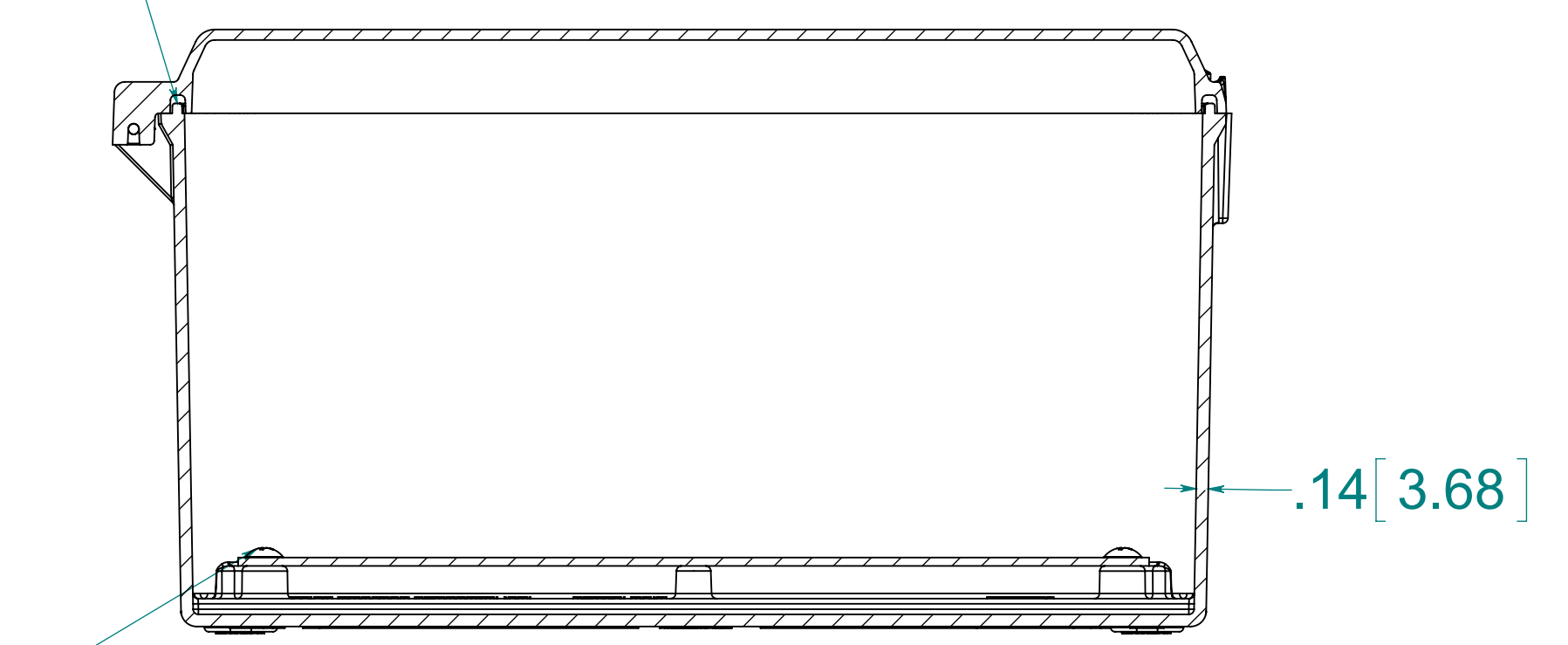

(4) EACH #10-32 BRASS INSERTS AND PLATED CARBON STEEL TRUSS SCREWS

SECTION B-B

FRONT VIEW WITH COVER REMOVED AND BACK PANEL DISPLAYED

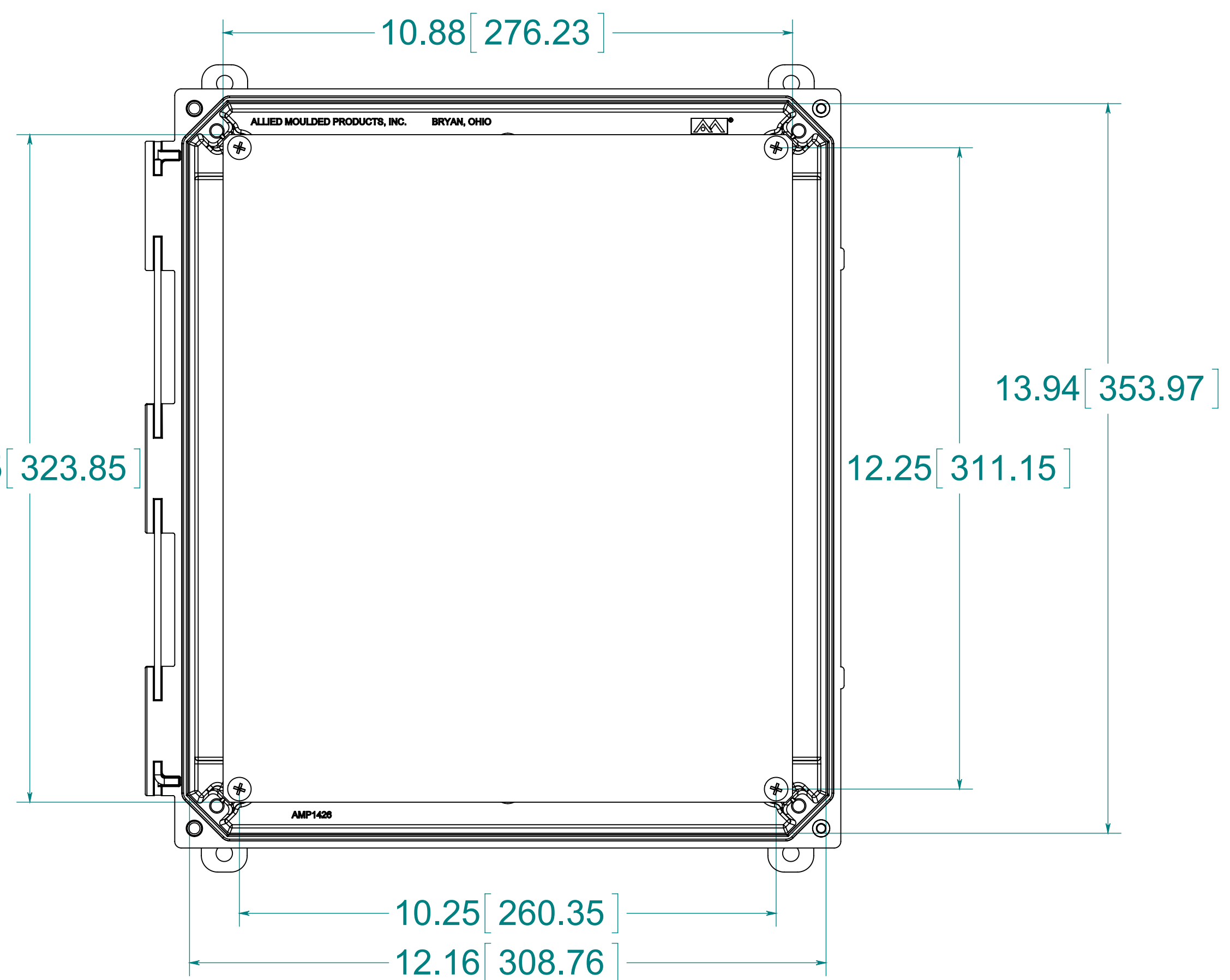

MATERIAL:  
 BOX- INJECTED POLYCARBONATE  
 STANDARD COVER- INJECTED POLYCARBONATE  
 CLEAR COVER - INJECTED POLYCARBONATE

CONFIDENTIAL  
 THIS MATERIAL IS OWNED BY THE ALLIED MOULDED PRODUCTS COMPANY. IS DISCLOSED IN CONFIDENCE, AND IS NOT TO BE REPRODUCED OR DISTRIBUTED WITHOUT PRIOR WRITTEN PERMISSION FROM ALLIED MOULDED PRODUCTS.



Description  
**POLYLINE™**  
 Part No.  
**AMP1426CCH**