

(4X) SNAP-IN POLYCARBONATE HINGE KNUCKLE

(4X) POLYCARBONATE FEET
(4X) #10-32 BRASS INSERTS, AND 316 STAINLESS STEEL FLANGE AND FEET SCREWS

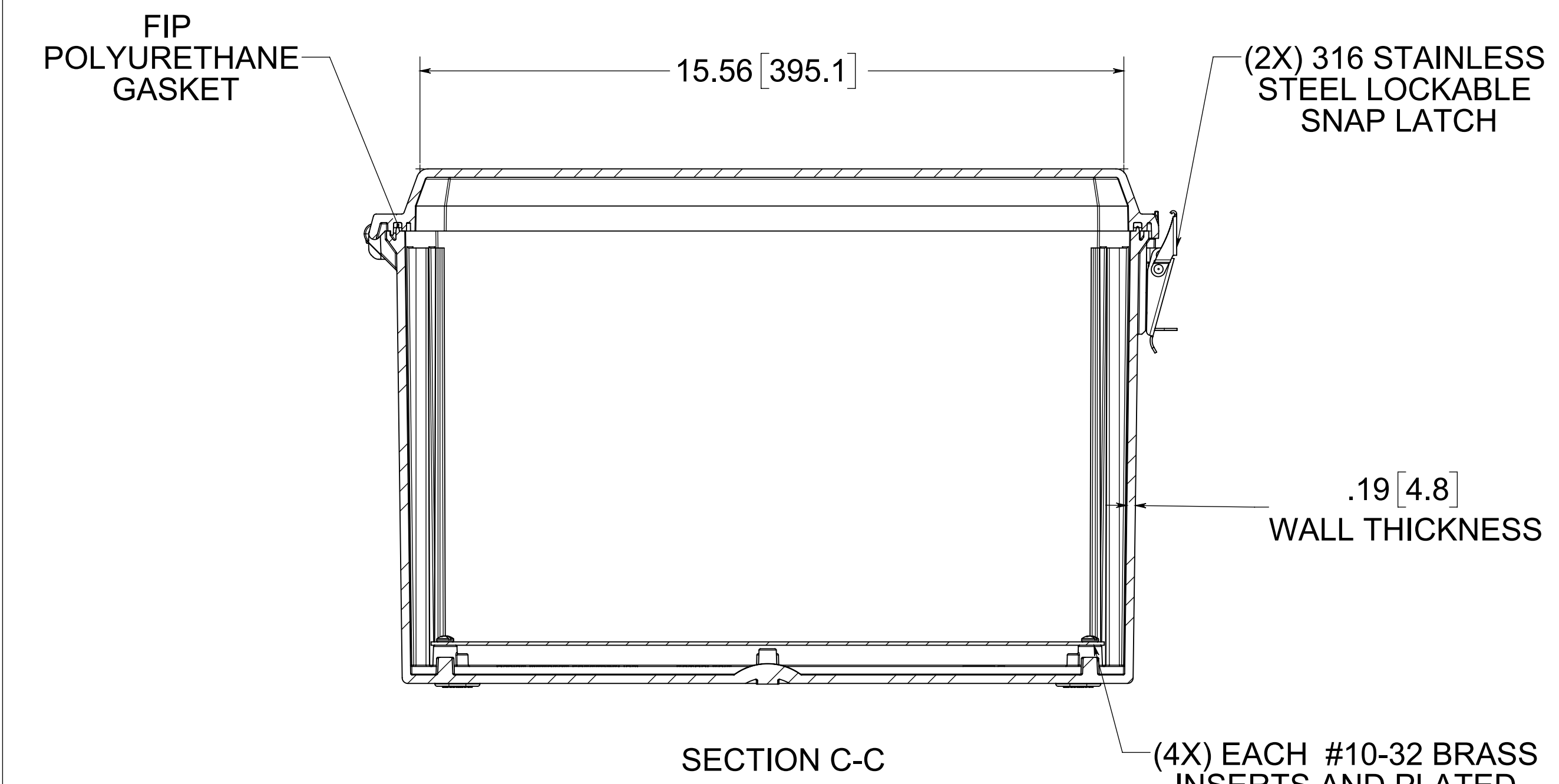

SECTION C-C

(4X) EACH #10-32 BRASS INSERTS AND PLATED CARBON STEEL SCREWS

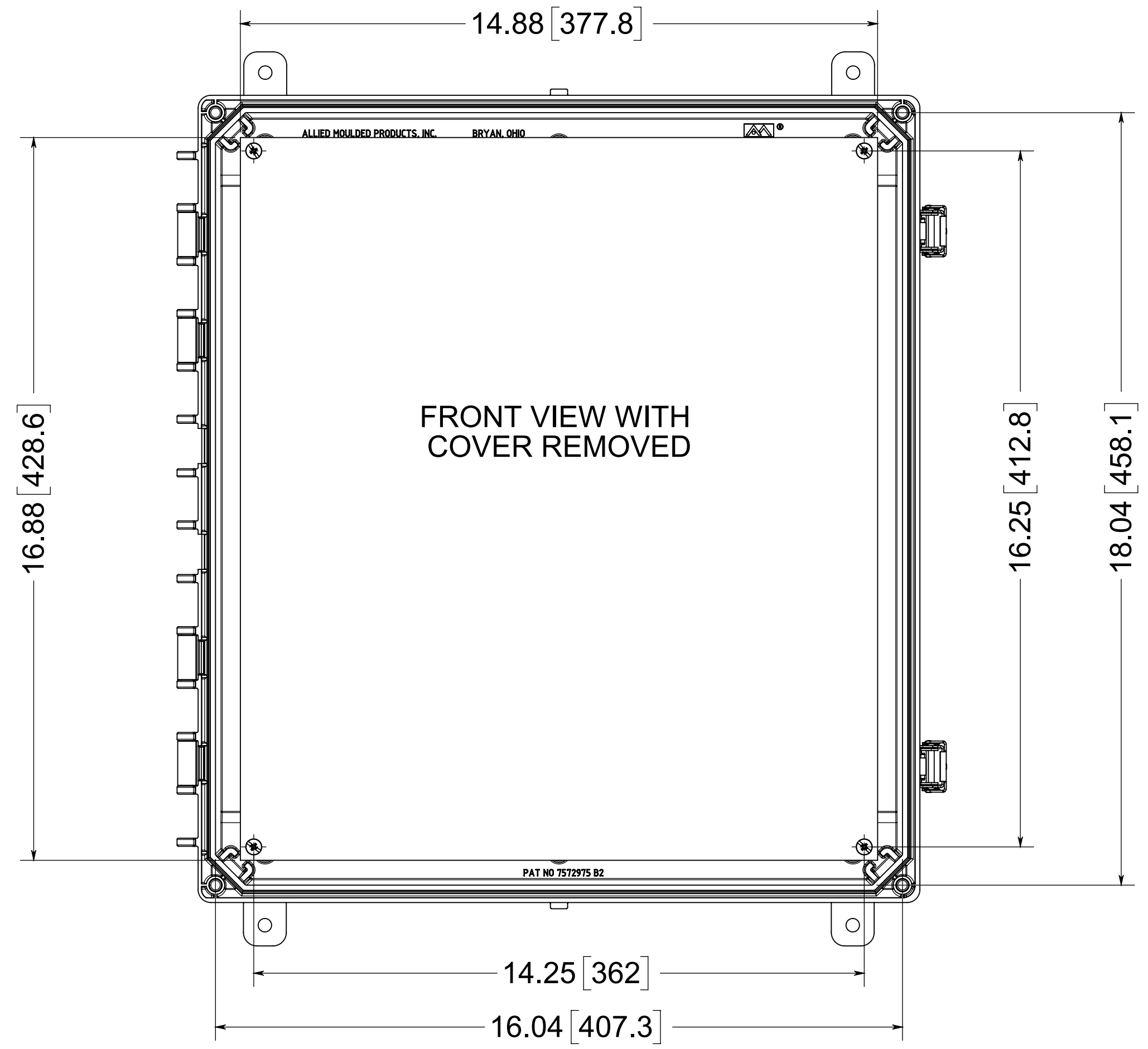

FRONT VIEW WITH COVER REMOVED

NOTE:
1. DATA SUBJECT TO CHANGE

MATERIAL:
BOX - INJECTION POLYCARBONATE
STANDARD COVER- INJECTION POLYCARBONATE
CLEAR COVER- INJECTION POLYCARBONATE

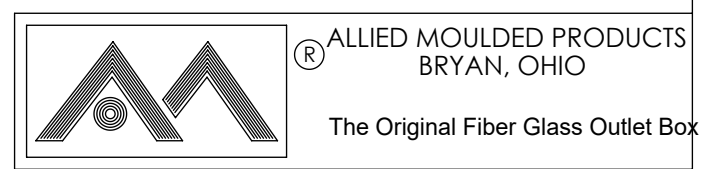

AMP Polyline
Part No. AMP1860CCL.WEB

CONFIDENTIAL
THIS MATERIAL IS OWNED BY THE ALLIED MOULDED PRODUCTS COMPANY, IS DISCLOSED IN CONFIDENCE, AND IS NOT TO BE REPRODUCED OR DISTRIBUTED WITHOUT PRIOR WRITTEN PERMISSION FROM ALLIED MOULDED PRODUCTS.