

(4) EACH #10-32 BRASS INSERTS AND 316 STAINLESS STEEL CAPTIVE COVER SCREWS

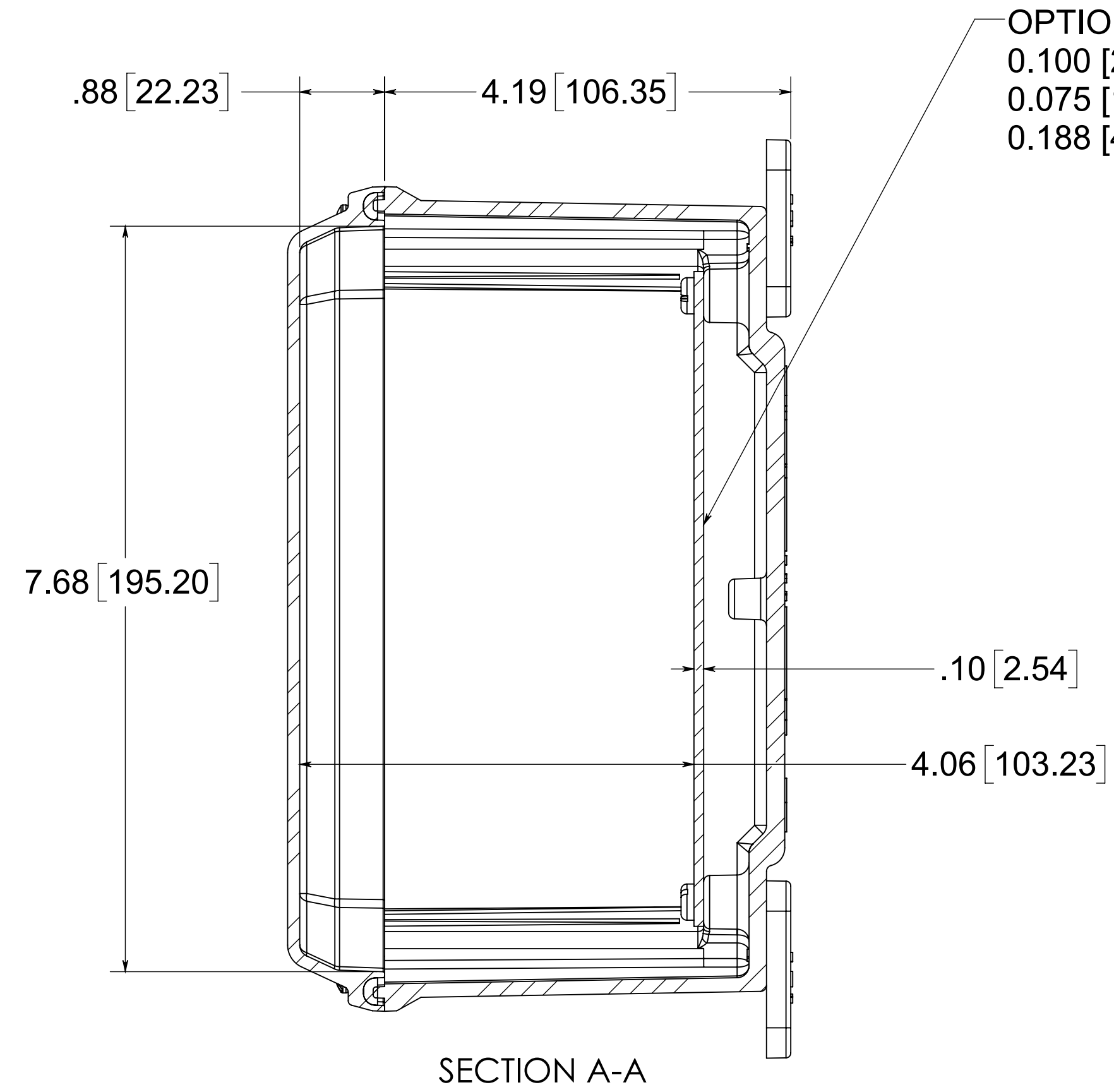

SECTION A-A

OPTIONAL BACK PANEL SHOWN
 0.100 [2.54mm] TH'K-ALUMINUM
 0.075 [1.91mm] TH'K-WHITE STEEL
 0.188 [4.78mm] TH'K-PVC

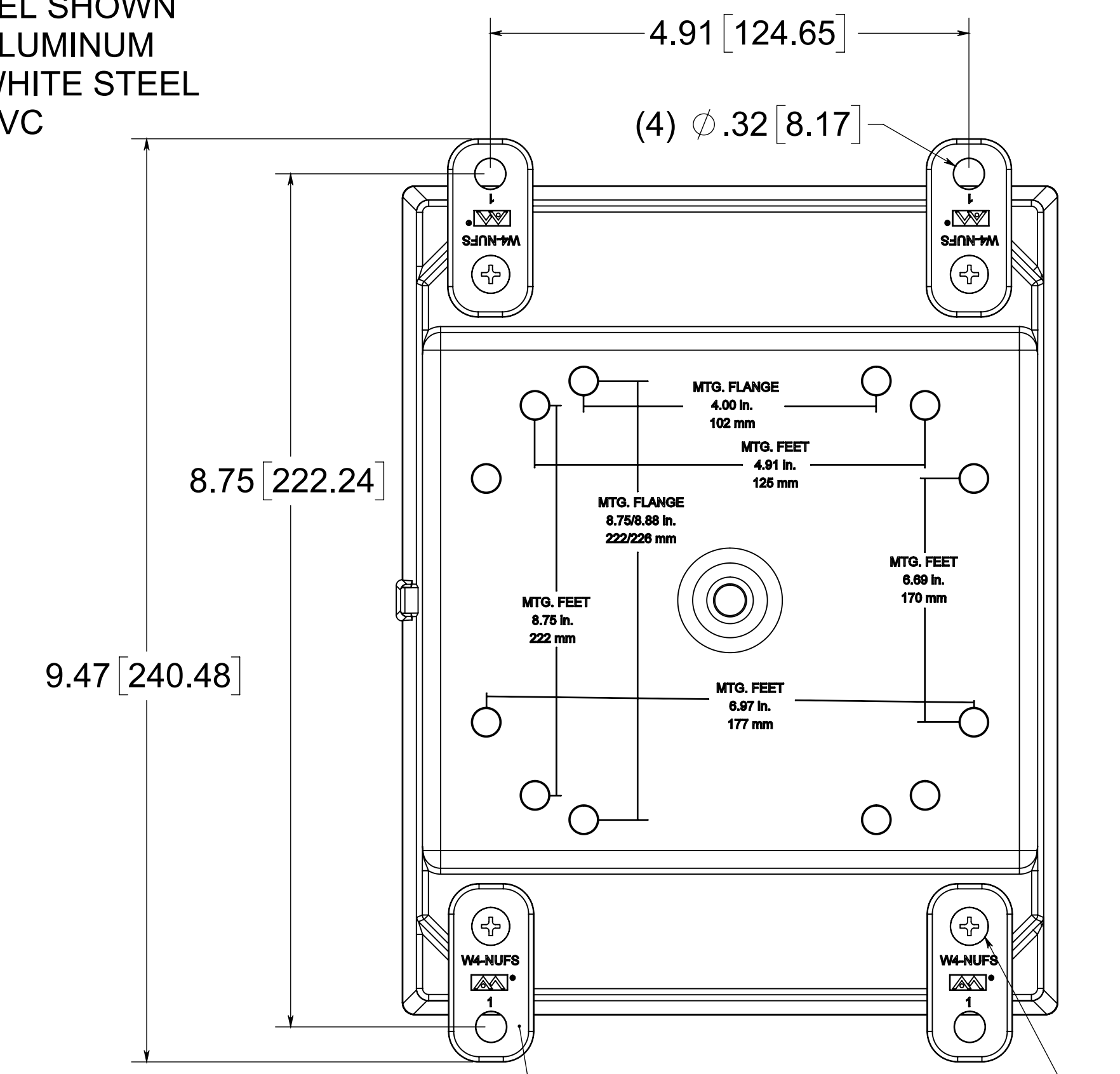

(4) POLYCARBONATE FEET

(4) EACH #10-32 BRASS INSERTS AND 316 STAINLESS STEEL FLANGE AND FEET SCREWS

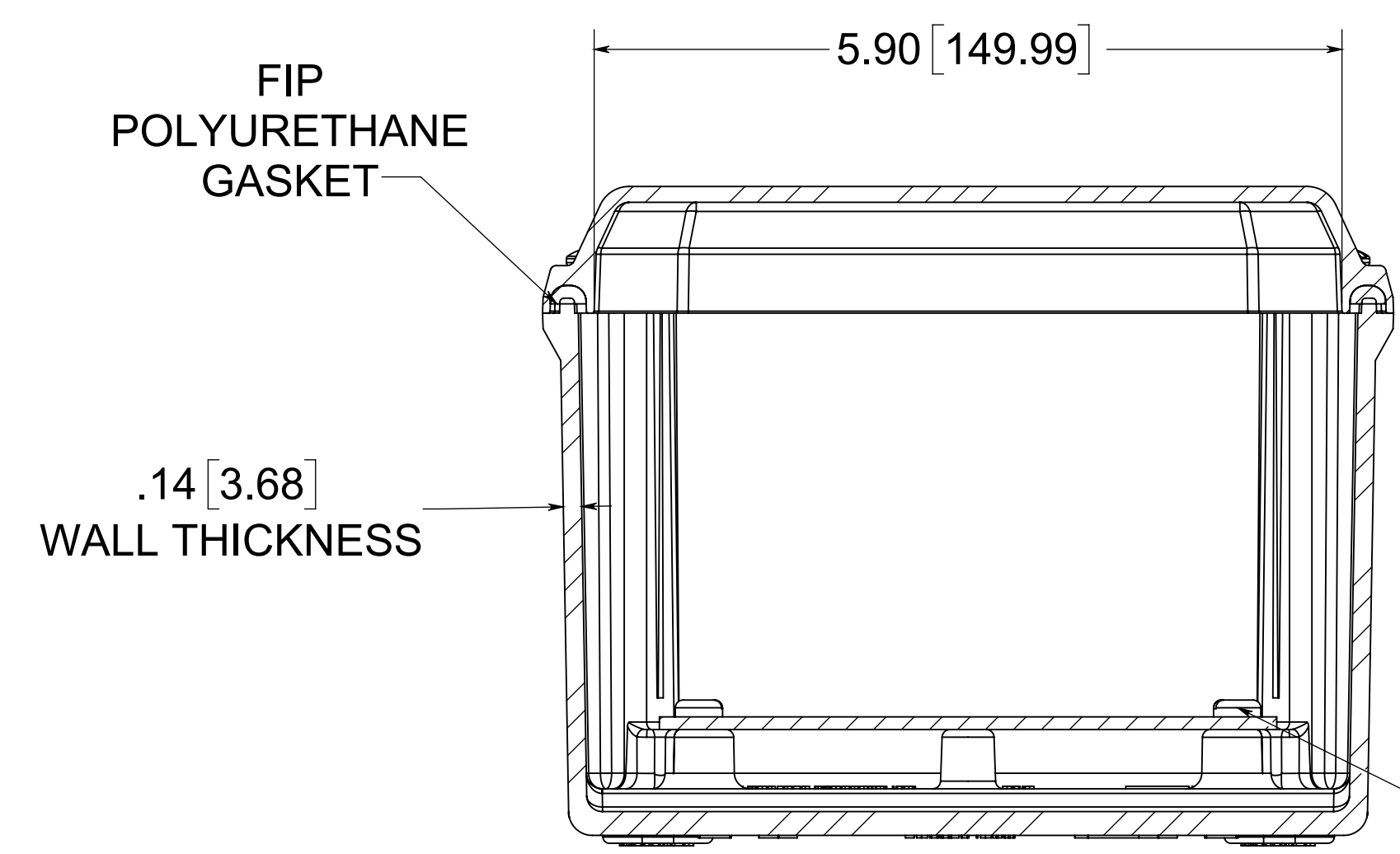

SECTION B-B

(4) EACH #10-32 BRASS INSERTS AND PLATED CARBON STEEL TRUSS SCREW

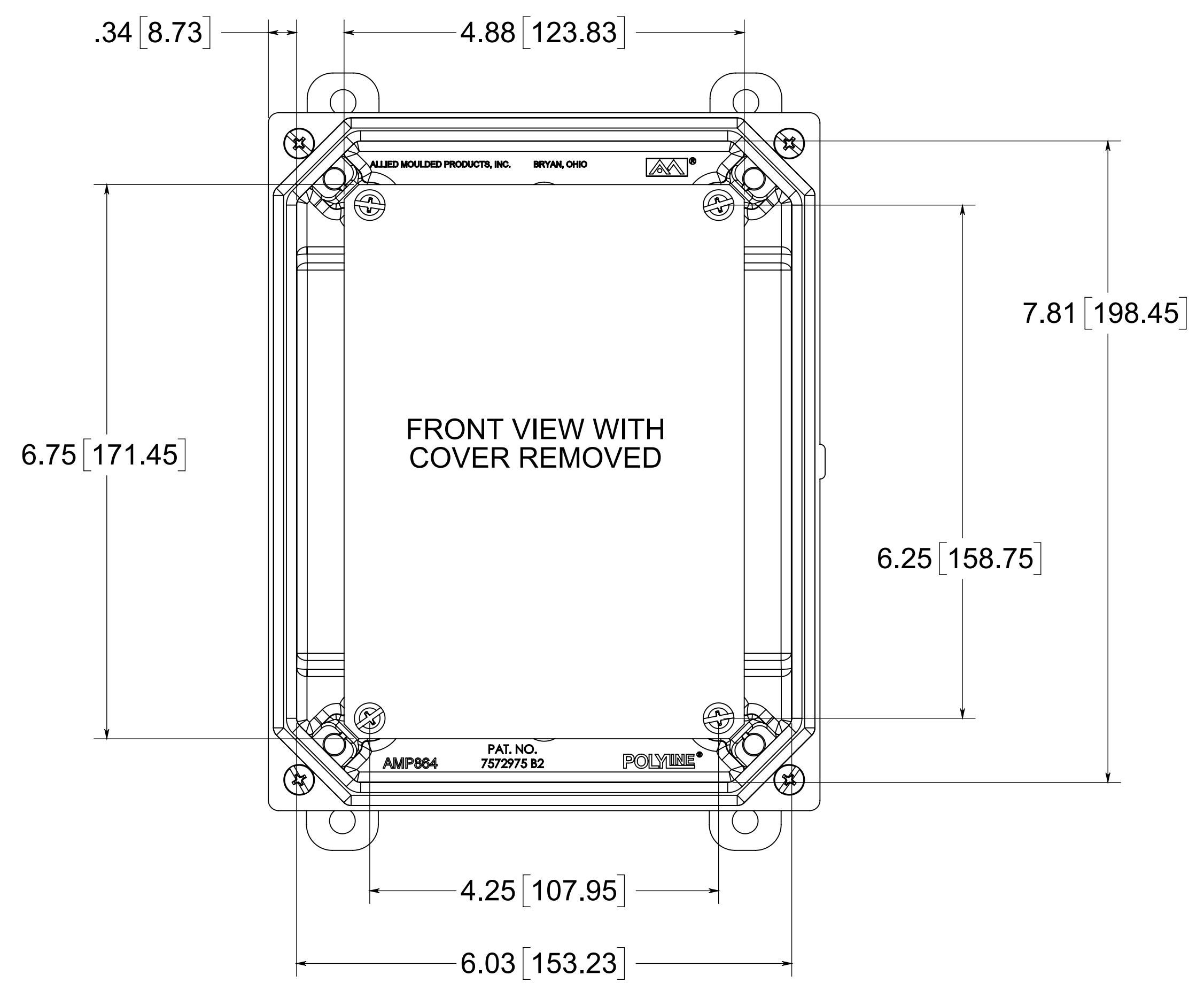

FRONT VIEW WITH COVER REMOVED

MATERIAL:
 BOX- INJECTED POLYCARBONATE
 STANDARD COVER- INJECTED POLYCARBONATE
 CLEAR COVER - INJECTED POLYCARBONATE

NOTE:
 1. DATA SUBJECT TO CHANGE WITHOUT NOTICE

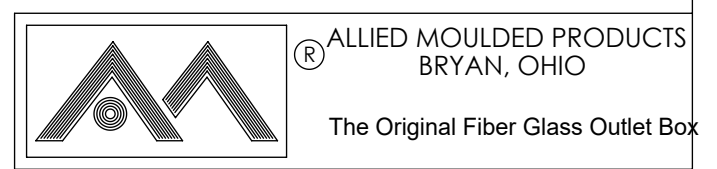

AMP Polyline
 AMP864CC

CONFIDENTIAL
 THIS MATERIAL IS OWNED BY THE ALLIED MOULDED PRODUCTS COMPANY, IS DISCLOSED IN CONFIDENCE, AND IS NOT TO BE REPRODUCED OR DISTRIBUTED WITHOUT PRIOR WRITTEN PERMISSION FROM ALLIED MOULDED PRODUCTS.