

OPTIONAL BACK PANEL
 0.100 [2.54] TH'K - ALUMINUM
 0.075 [1.91] TH'K - WHITE STEEL & GALVANNEALED
 0.125 [3.18] TH'K - FIBERGLASS

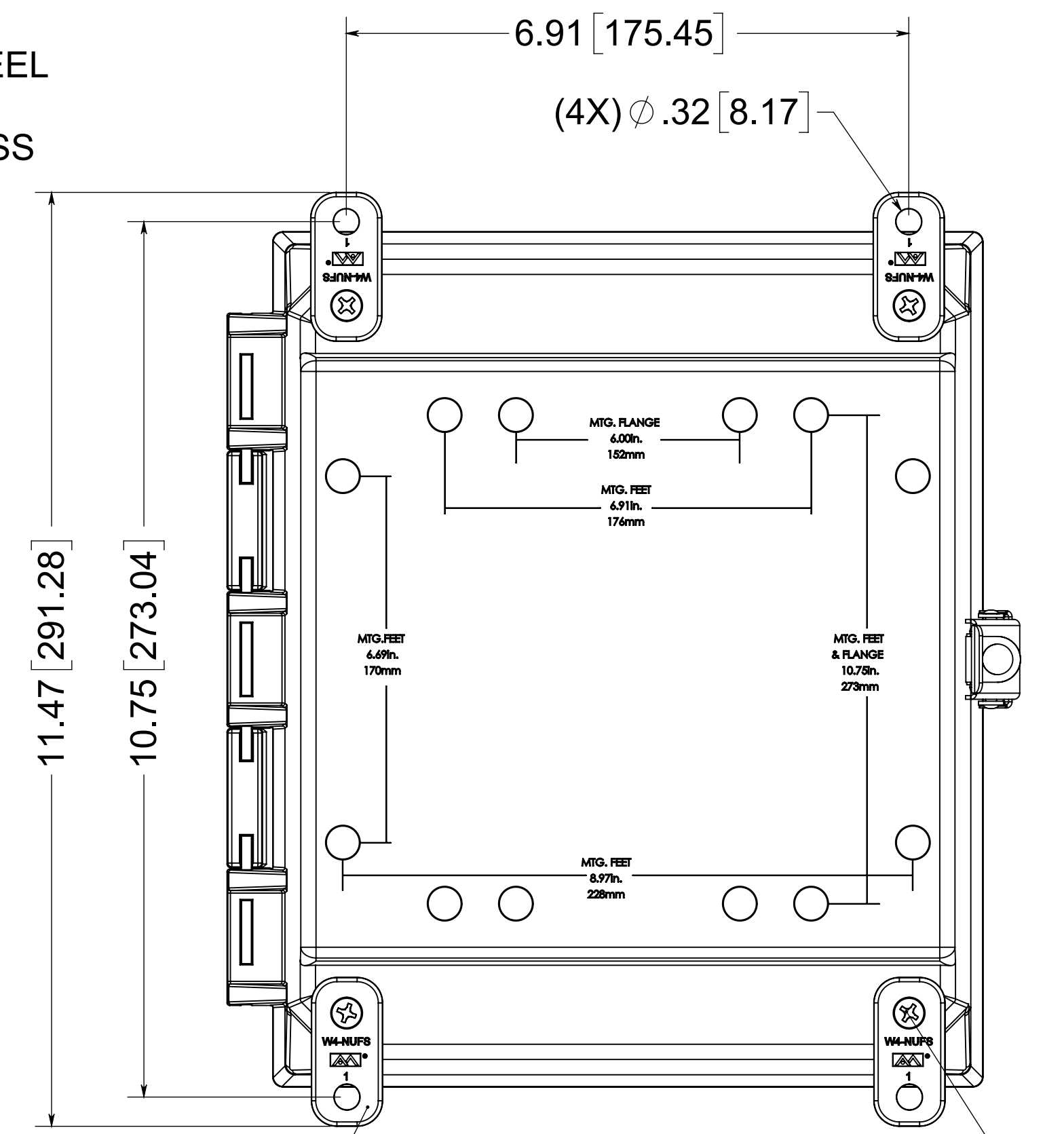

(4X) POLYCARBONATE FEET
 (4X) EACH #10-32 BRASS INSERTS, AND 316 STAINLESS STEEL FEET SCREWS

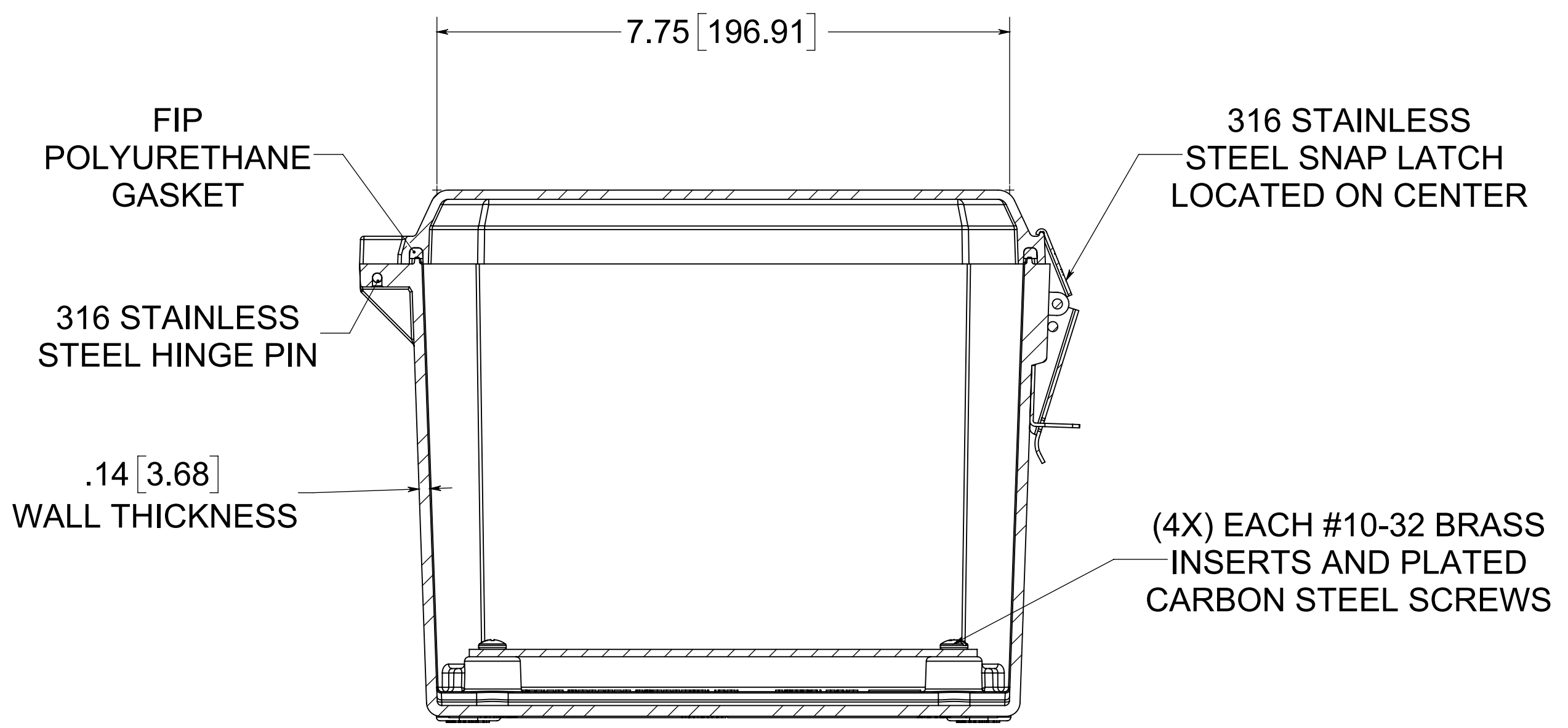

SECTION A-A

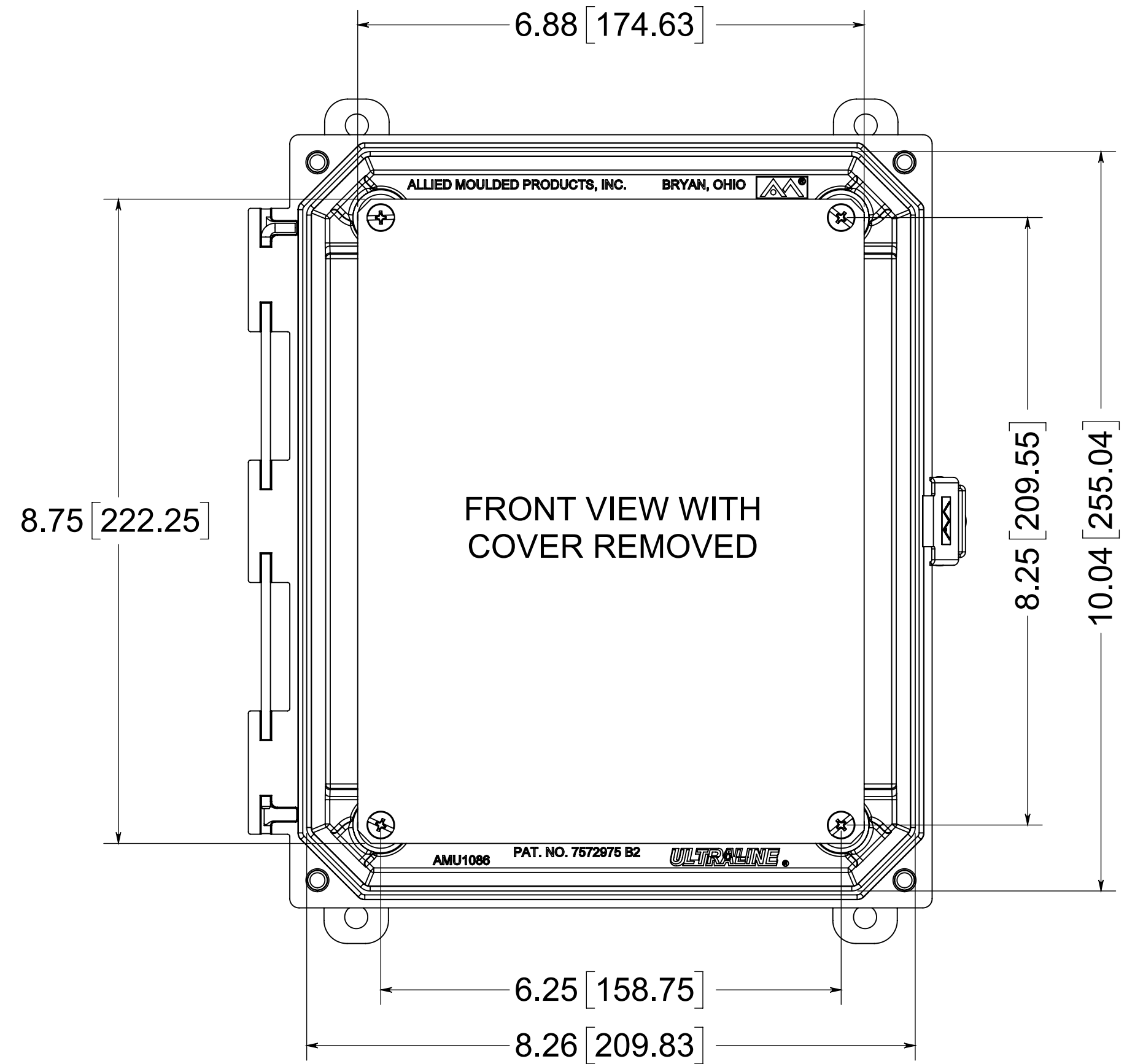

FRONT VIEW WITH COVER REMOVED

MATERIAL:
 BOX - COMPRESSION MOLDED FIBERGLASS REINFORCED POLYESTER
 COVER - COMPRESSION MOLDED FIBERGLASS REINFORCED POLYESTER
 CLEAR COVER - INJECTED POLYCARBONATE

NOTE:
 1. DATA SUBJECT TO CHANGE WITHOUT NOTICE

ALLIED MOULDED PRODUCTS, INC. BRYAN, OHIO
 The Original Fiber Glass Outlet Box

AMU Ultraline
 AMU1086CCL

CONFIDENTIAL
 THIS MATERIAL IS OWNED BY THE ALLIED MOULDED PRODUCTS COMPANY, IS DISCLOSED IN CONFIDENCE, AND IS NOT TO BE REPRODUCED OR DISTRIBUTED WITHOUT PRIOR WRITTEN PERMISSION FROM ALLIED MOULDED PRODUCTS.
 © Allied Moulded Products, Inc. All Rights Reserved