

OPTIONAL BACK PANEL
 0.100 [2.54] TH'K - ALUMINUM
 0.075 [1.91] TH'K - WHITE STEEL &
 GALVANNEALED
 0.125 [3.18] TH'K - FIBERGLASS

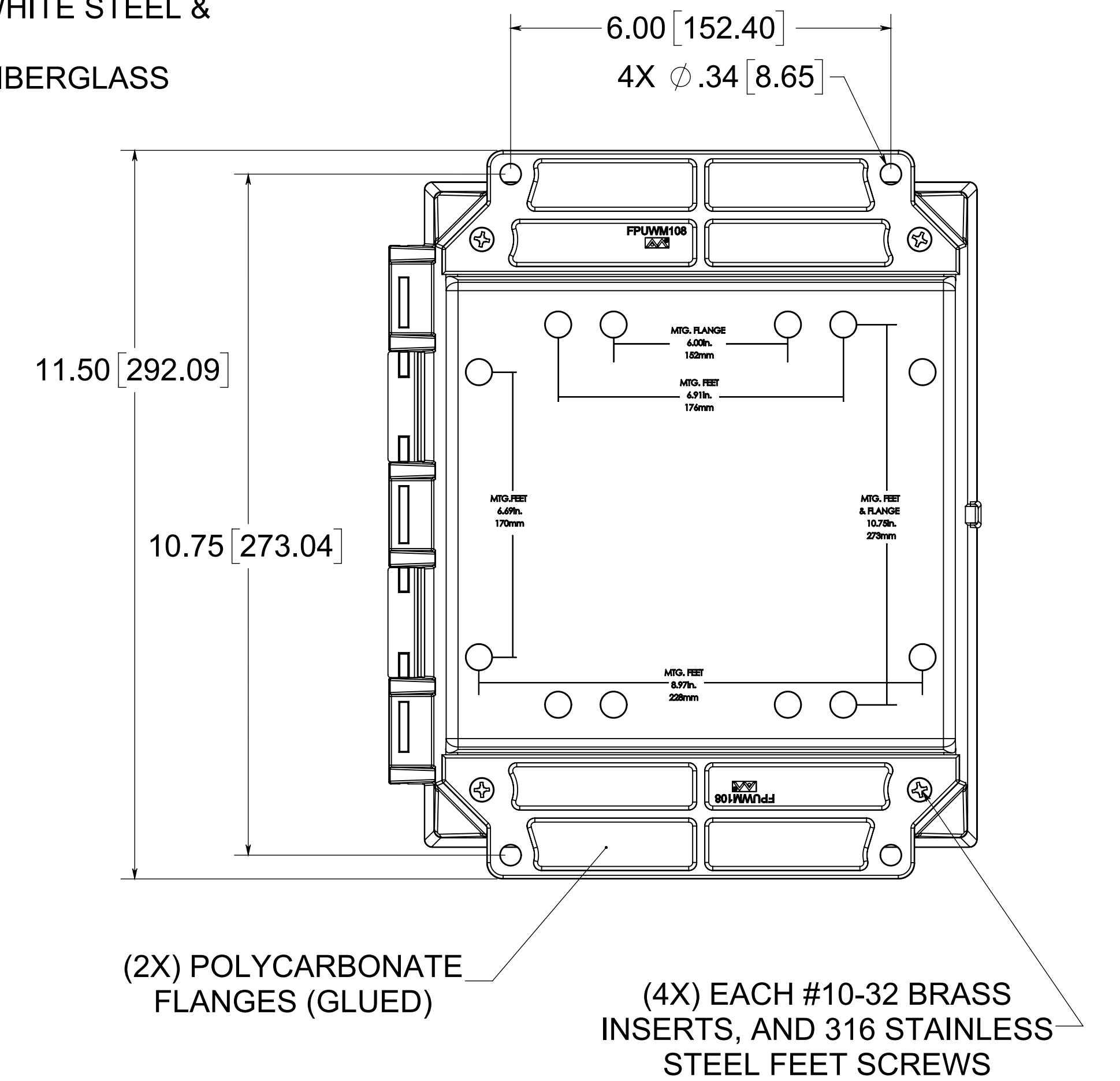

(2X) POLYCARBONATE
 FLANGES (GLUED)

(4X) EACH #10-32 BRASS
 INSERTS, AND 316 STAINLESS
 STEEL FEET SCREWS

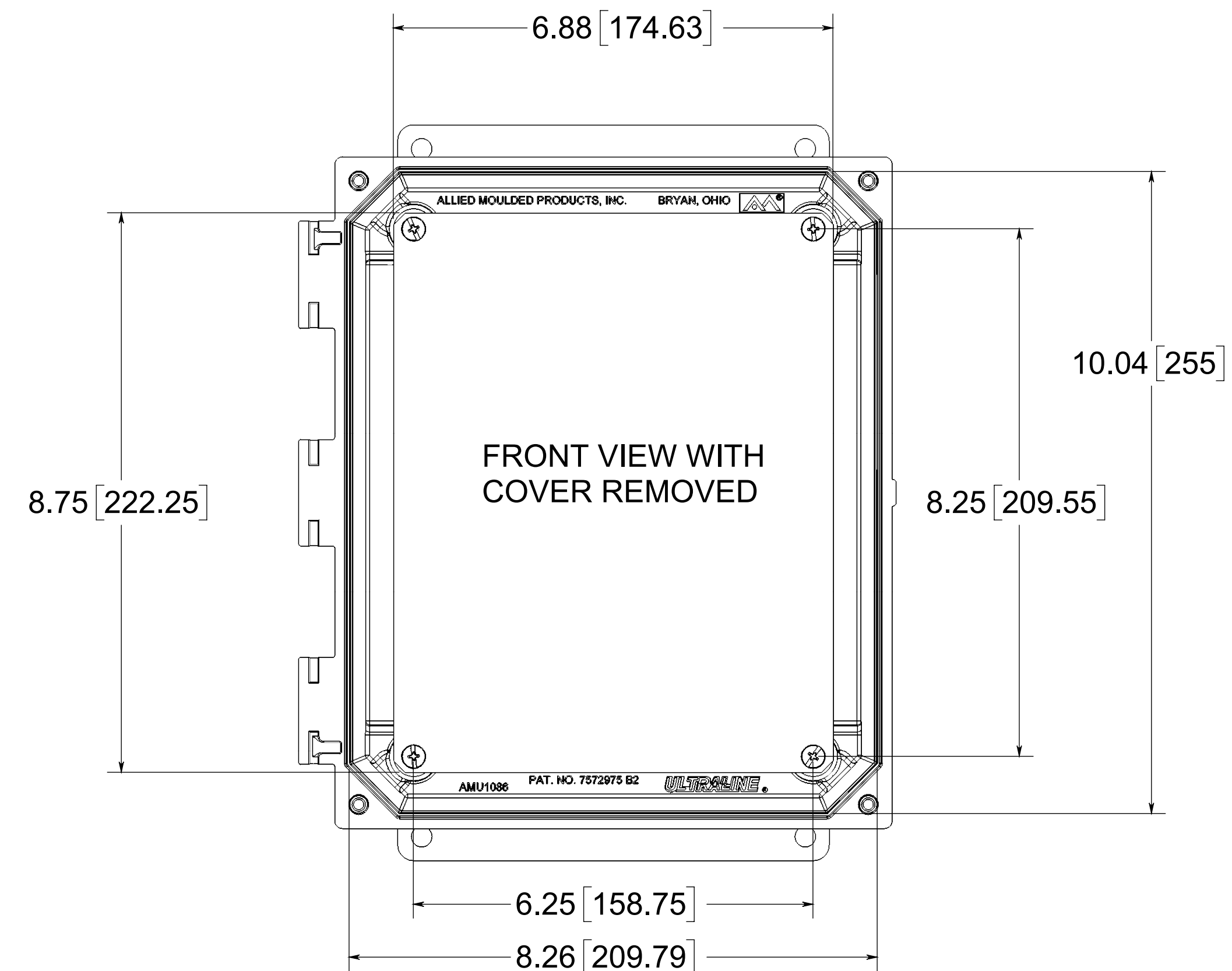
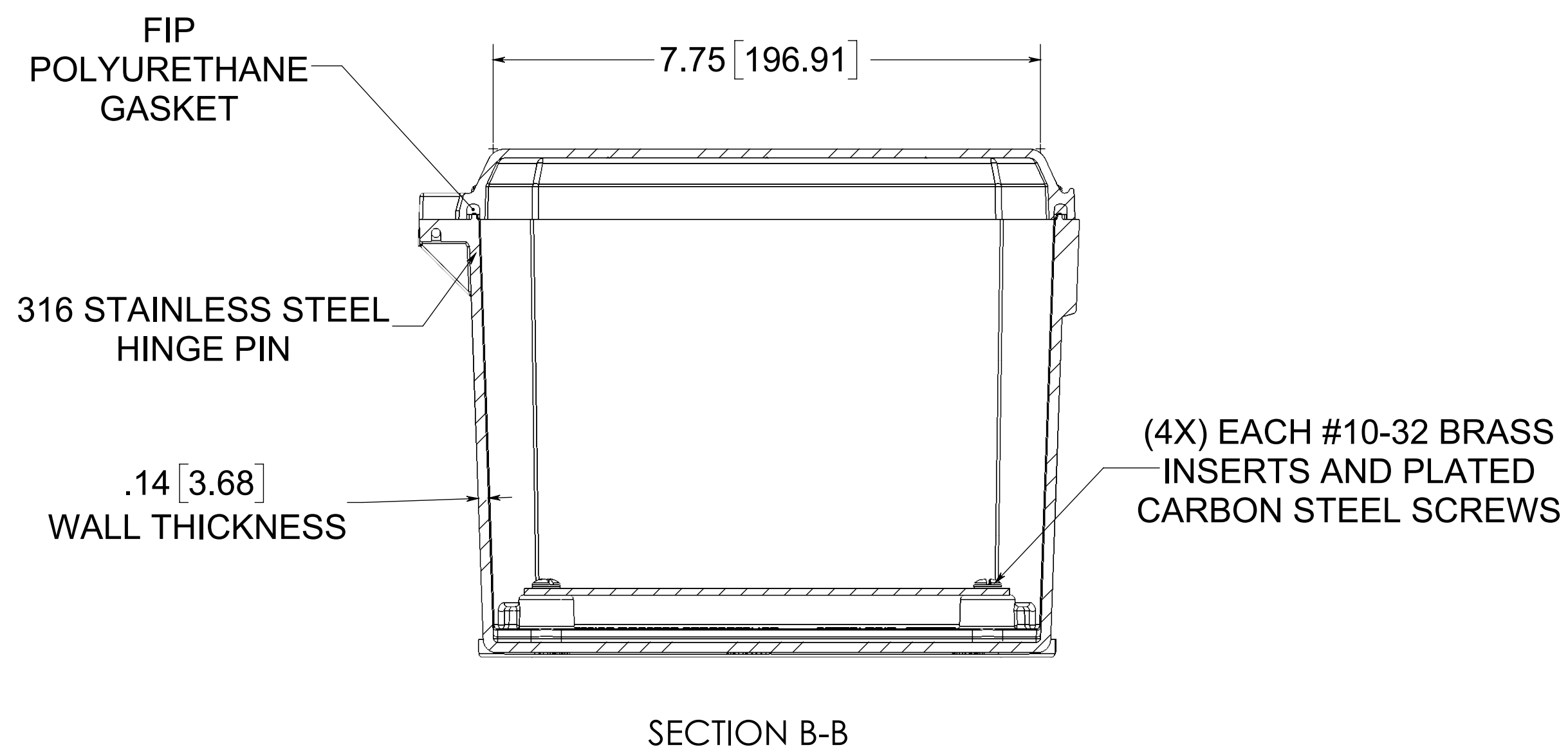

NOTE:
 1. DATA SUBJECT TO
 CHANGE WITHOUT NOTICE

MATERIAL:
 BOX - COMPRESSION MOLDED FIBERGLASS REINFORCED POLYESTER
 COVER - COMPRESSION MOLDED FIBERGLASS REINFORCED POLYESTER
 CLEAR COVER - INJECTED POLYCARBONATE

CONFIDENTIAL
 THIS MATERIAL IS OWNED BY THE ALLIED
 MOULDED PRODUCTS COMPANY, IS DISCLOSED
 IN CONFIDENCE, AND IS NOT TO BE REPRODUCED
 OR DISTRIBUTED WITHOUT PRIOR WRITTEN
 PERMISSION FROM ALLIED MOULDED PRODUCTS.
 © Allied Moulded Products, Inc.
 All Rights Reserved

ALLIED MOULDED PRODUCTS
 BRYAN, OHIO
 The Original Fiber Glass Outlet Box

Description
AMU Ultraline
 Part No.
AMU1086F