

OPTIONAL BACK PANEL
 0.100 [2.54] TH'K - ALUMINUM
 0.075 [1.91] TH'K - WHITE STEEL & GALVANNEALED
 0.125 [3.18] TH'K - FIBERGLASS

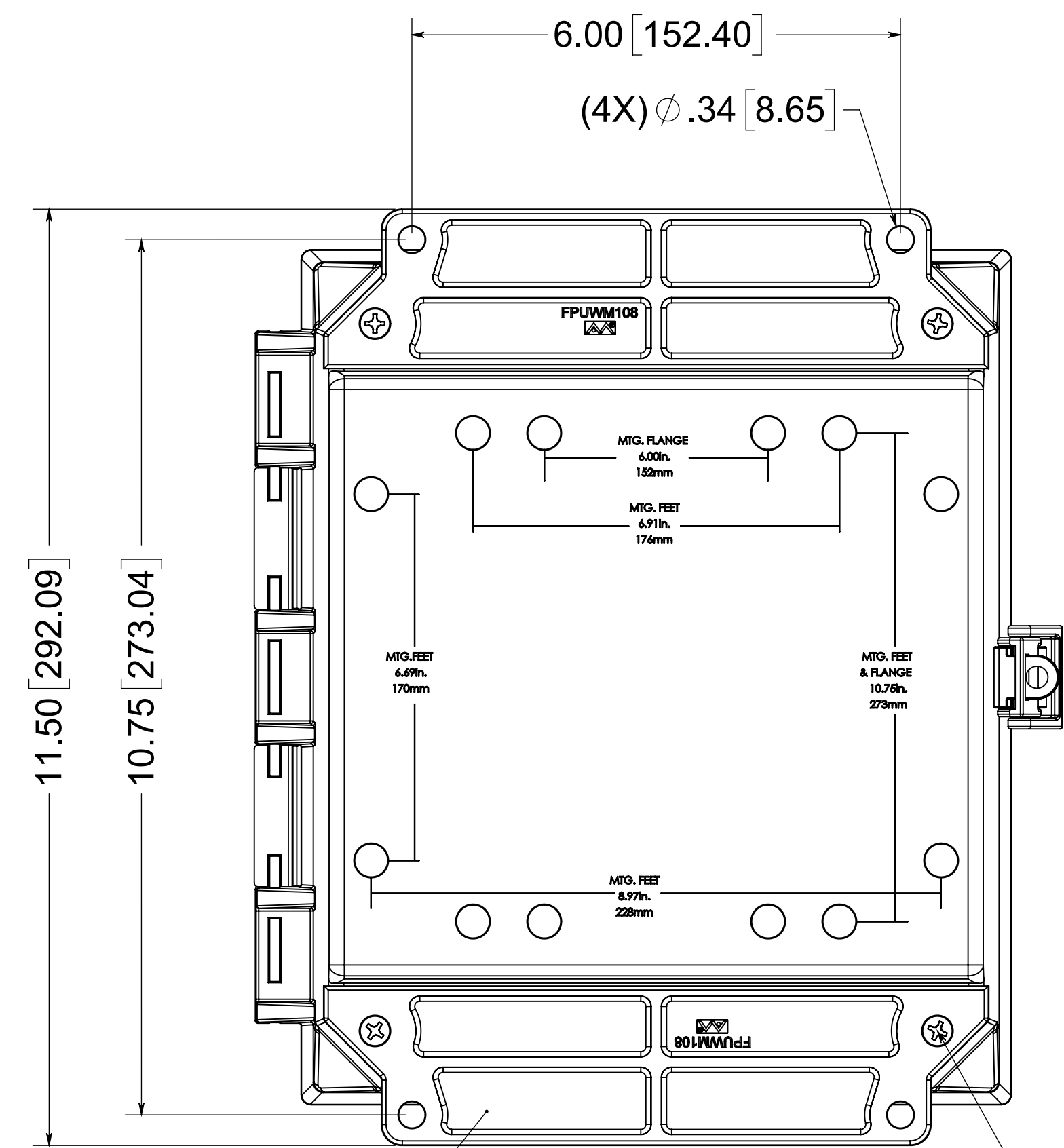

(2X) POLYCARBONATE FLANGES (GLUED)
 (4X) EACH #10-32 BRASS INSERTS, AND 316 STAINLESS STEEL FLANGE SCREWS

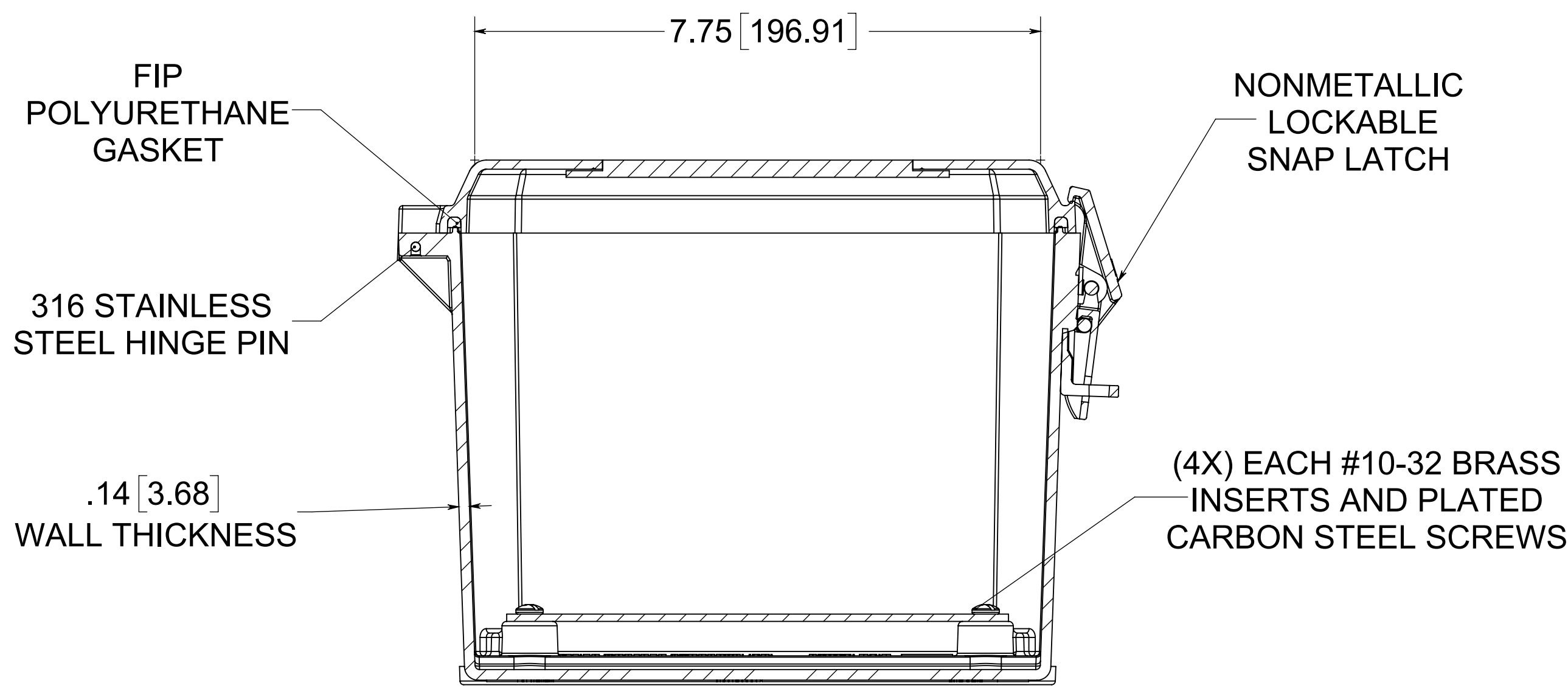

SECTION A-A

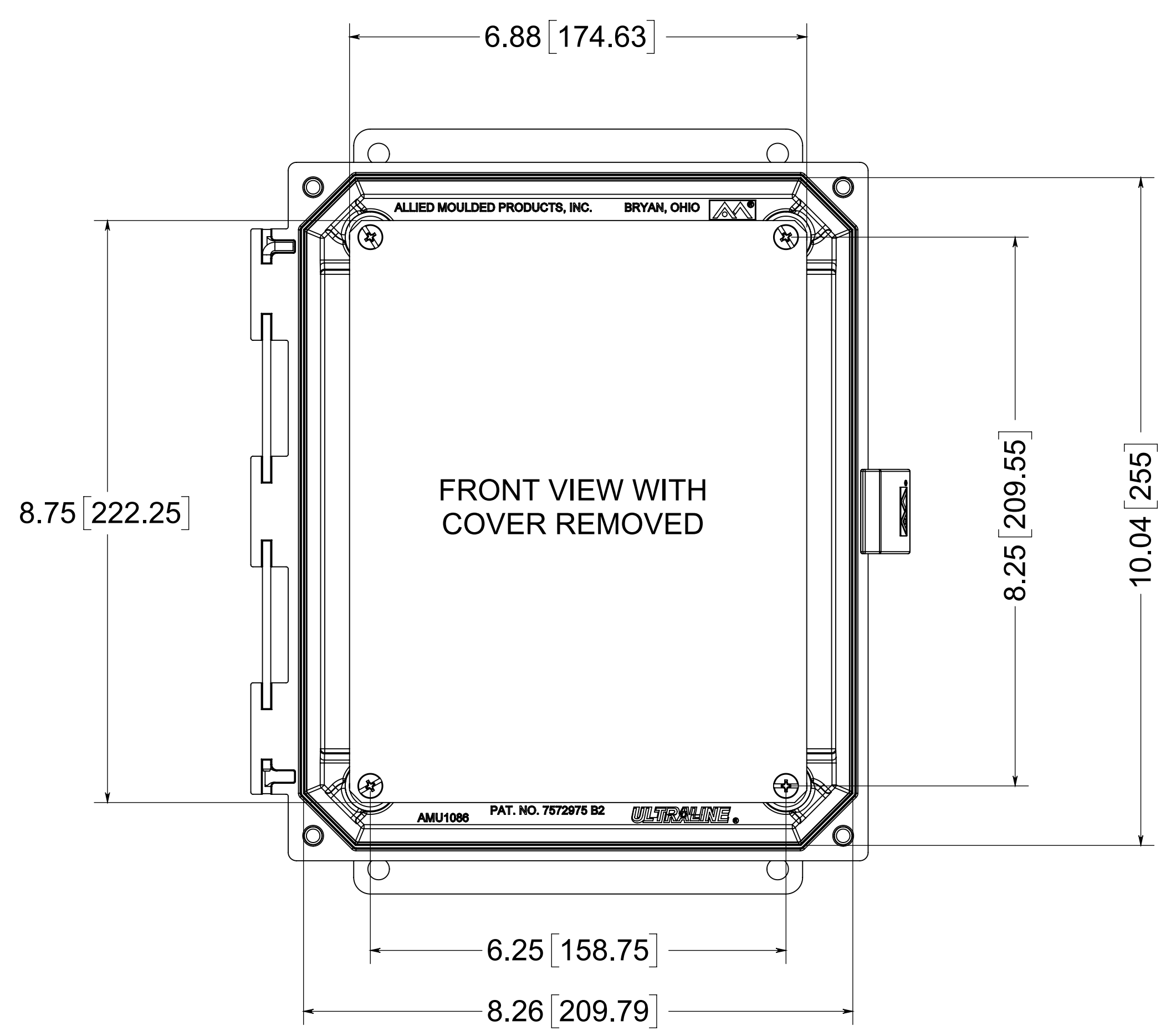

ALLIED MOULDED PRODUCTS, INC. BRYAN, OHIO

AMU1086 PAT. NO. 7572075 B2 ULTRALINE

MATERIAL:
 BOX - COMPRESSION MOLDED FIBERGLASS REINFORCED POLYESTER
 COVER - COMPRESSION MOLDED FIBERGLASS REINFORCED POLYESTER
 WINDOW - POLYCARBONATE

NOTE:
 1. DATA SUBJECT TO CHANGE WITHOUT NOTICE

CONFIDENTIAL
 THIS MATERIAL IS OWNED BY THE ALLIED MOULDED PRODUCTS COMPANY, IS DISCLOSED IN CONFIDENCE, AND IS NOT TO BE REPRODUCED OR DISTRIBUTED WITHOUT PRIOR WRITTEN PERMISSION FROM ALLIED MOULDED PRODUCTS.
 © Allied Moulded Products, Inc. All Rights Reserved

ALLIED MOULDED PRODUCTS BRYAN, OHIO
 The Original Fiber Glass Outlet Box

AMU Ultraline
 Part No. AMU1086NLWF