

(4X) EACH #10-32 BRASS INSERTS, AND 316 STAINLESS STEEL CAPTIVE COVER SCREWS

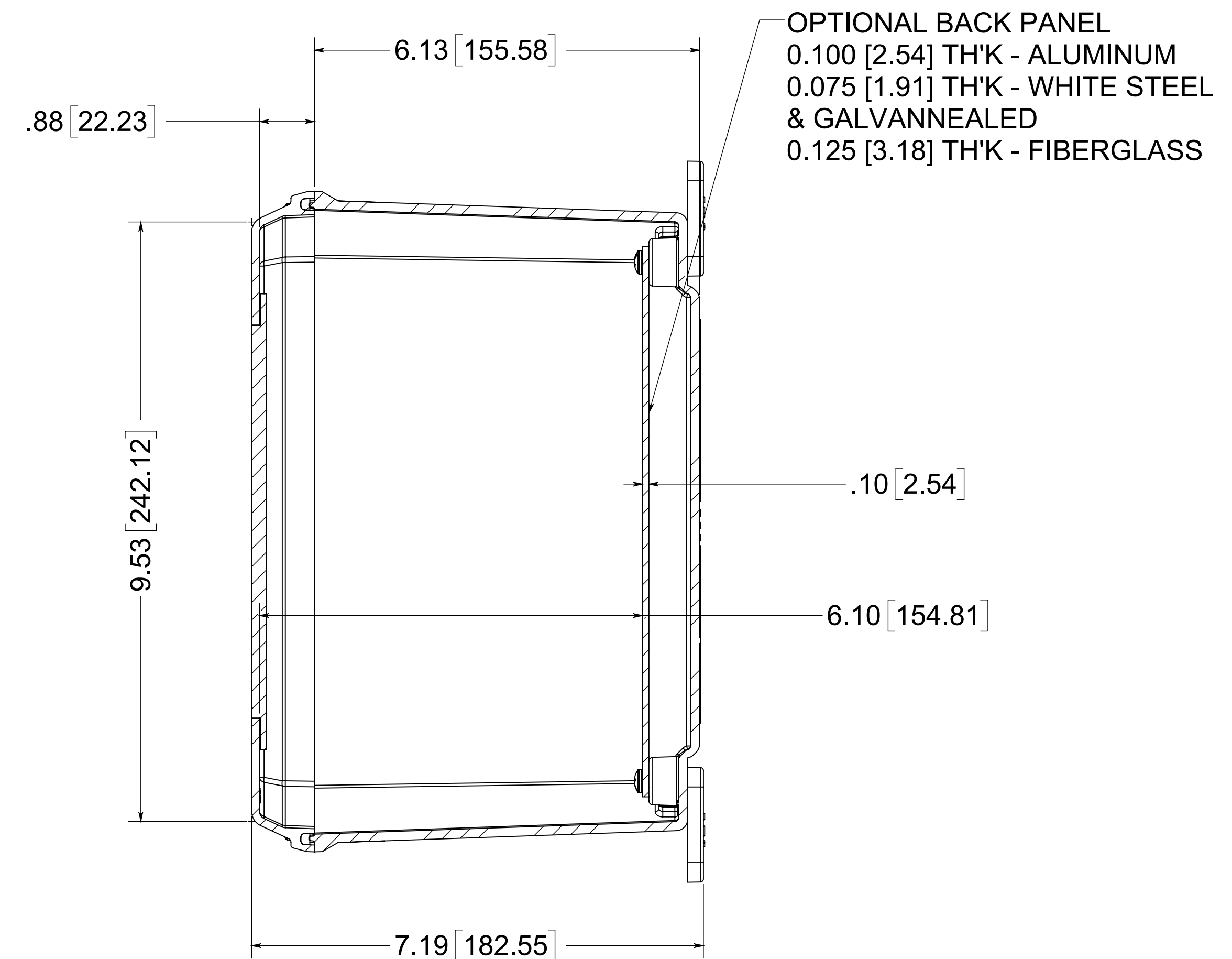

SECTION B-B

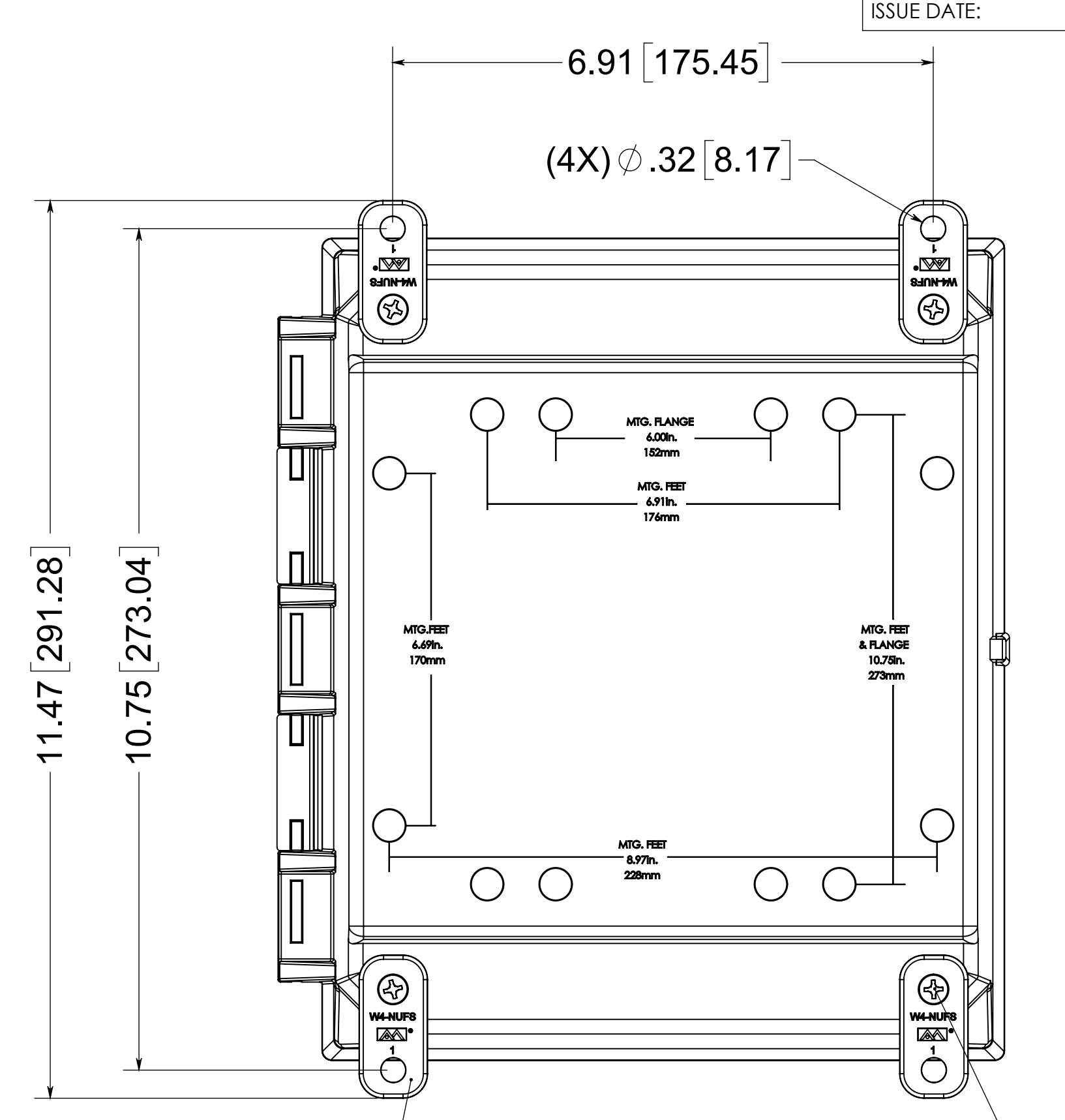

(4X) POLYCARBONATE FEET

(4X) EACH #10-32 BRASS INSERTS, AND 316 STAINLESS STEEL FEET SCREWS

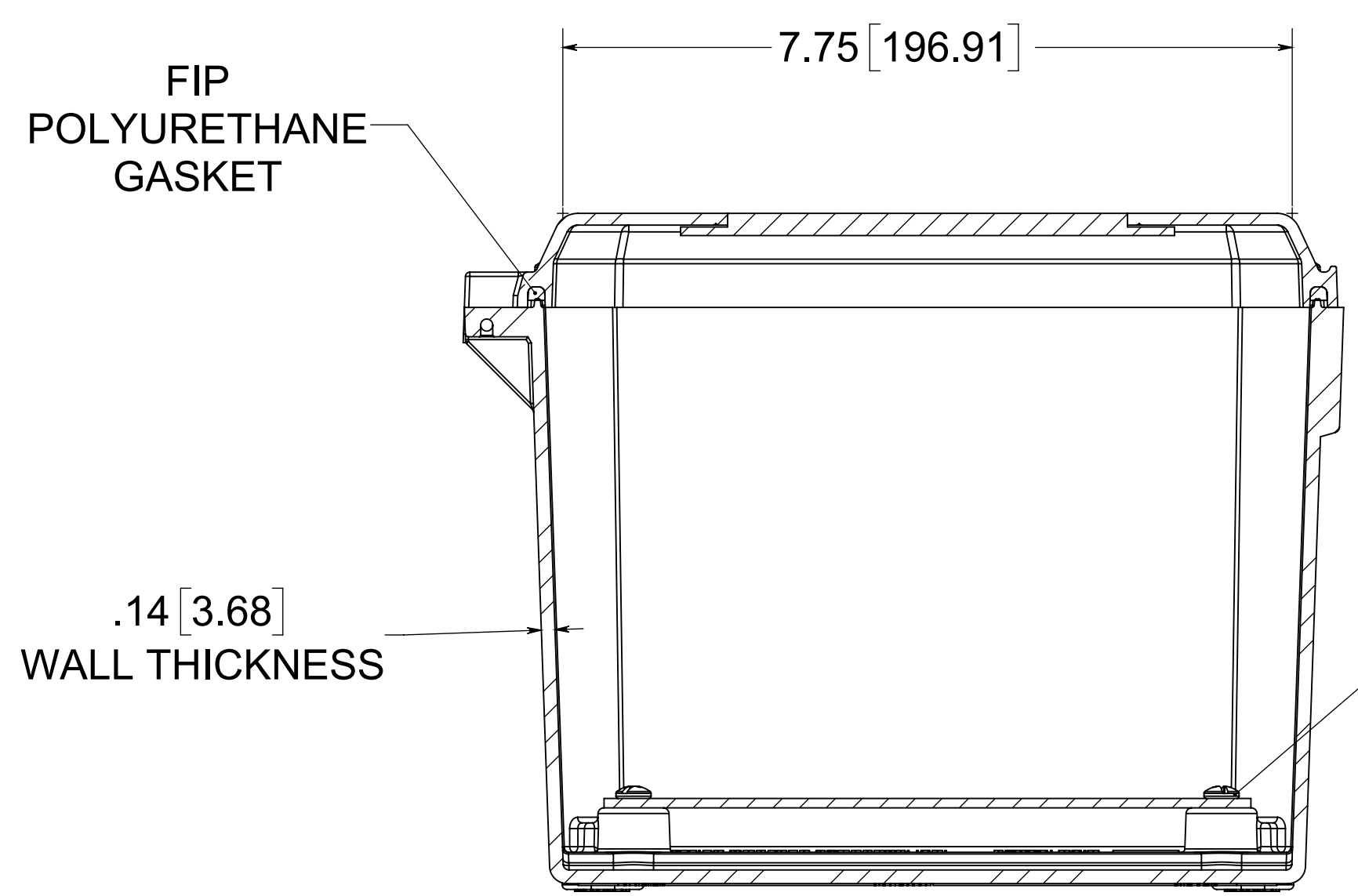

SECTION A-A

(4X) EACH #10-32 BRASS INSERTS AND PLATED CARBON STEEL SCREWS

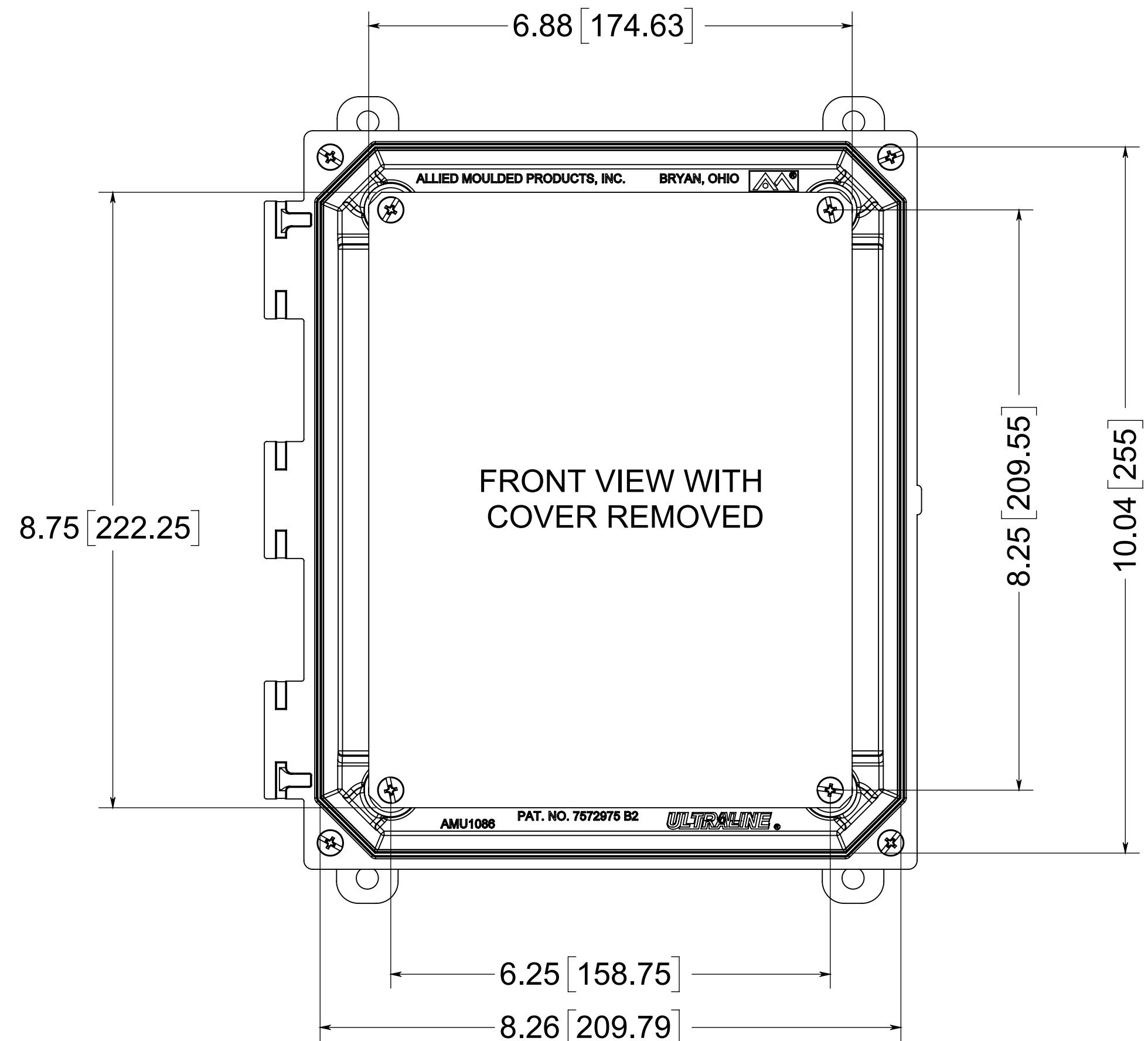

FRONT VIEW WITH COVER REMOVED

MATERIAL:
 BOX - COMPRESSION MOLDED FIBERGLASS REINFORCED POLYESTER
 COVER - COMPRESSION MOLDED FIBERGLASS REINFORCED POLYESTER
 WINDOW - POLYCARBONATE

NOTE:
 1. DATA SUBJECT TO CHANGE WITHOUT NOTICE

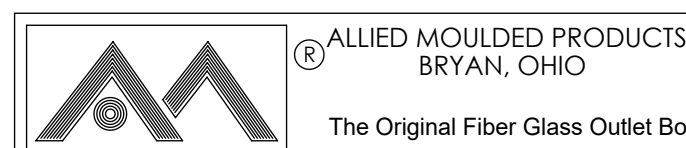

CONFIDENTIAL
 THIS MATERIAL IS OWNED BY THE ALLIED MOULDED PRODUCTS COMPANY, IS DISCLOSED IN CONFIDENCE, AND IS NOT TO BE REPRODUCED OR DISTRIBUTED WITHOUT PRIOR WRITTEN PERMISSION FROM ALLIED MOULDED PRODUCTS.
 © Allied Moulded Products, Inc. All Rights Reserved

Description
AMU Ultraline
AMU1086W
 Part No.